

# REGION 28 PLANNING UPDATE COMMITTEE

SERVING EASTERN PENNSYLVANIA, SOUTHERN NEW JERSEY AND DELAWARE



**REGION 28 PLAN**  
**(As defined in)**  
**FCC Gen. Docket No. 87-112**  
**AND APPROVED BY THE FCC ON FEBRUARY 2, 1990**  
**AND AMENDED BY FCC Gen Docket No. 89-573 on DECEMBER 27, 1993**

Richard R. Reynolds, Chairman,  
OFC: (302) 739-9648 FAX: (302) 739-9642  
Judith R. Brackin, Secretary  
OFC: (610) 344-5000 FAX: (610) 344-5050



**REGION 28 PLAN**  
**(As defined in)**  
**FCC Gen. Docket No. 87-112**

**TABLE OF CONTENTS**

FORWARD .....	1
Future Planning Requirements .....	1
SCOPE.....	2
Introduction .....	2
Purpose.....	2
Coordination with Adjacent Regions.....	2
Flexibility of the Plan .....	3
AUTHORITY .....	4
Regional Planning Committee.....	4
National Interrelationships .....	4
Federal Interoperability .....	4
Regional Plan Update Committee .....	5
SPECTRUM UTILIZATION .....	6
Region Defined.....	6
Usage Guidelines .....	6
Reassignment of Frequencies .....	7
SUPPLEMENT TO THE APPLICATION FORM .....	8
COMMUNICATIONS REQUIREMENTS.....	9
Common Channel Implementation.....	9
Areas of Operation .....	9
Operation of the Common Channels .....	9
Sub Regions.....	9
OPERATING PROCEDURES .....	9
Vocabulary .....	9
Calling Channel (ICALL).....	9
Tactical Channels (ITAC 1 - ITAC 4).....	9
Schedule of Tactical Channel Assignments.....	10
Network Operation Method.....	11
Encryption Standards.....	11
Use of Long Range Communications.....	11
Use of Cellular Telephone.....	11
IMPLEMENTATION AND PROCEDURES .....	12

Notification.....	12
Evaluation Sub-Committee.....	12
Frequency Allocation Process .....	12
EVALUATION MATRIX .....	13
I. SERVICE .....	13
II. INTEROPERABILITY .....	13
III. LOADING .....	13
IV. SPECTRUM EFFICIENT TECHNOLOGY.....	13
V. SYSTEMS IMPLEMENTATION FACTORS.....	13
VI. GEOGRAPHIC EFFICIENCY .....	13
VII. GIVEBACKS .....	13
Implementation Schedules (Slow Growth) .....	14
Appeal Process .....	14
EPILOGUE.....	15
APPENDICES .....	17
Appendix A      Evaluation Matrix .....	18
Appendix B      Point Assignment Criteria.....	26
Appendix C      Population in Regional Planning Area.....	31
Appendix D      Population Density in Regional Planning Area.....	33
Appendix E      Regional Planning Area Map.....	35
Appendix F      Frequency Assignment Methodology & Channel Assignments.....	37
Appendix G      Committee Members - Task Groups - Subcommittees .....	44
Appendix H      Convening Meeting Notification List .....	53
Appendix I      Committee Rules.....	57
Appendix J      Participating Agencies .....	58
Appendix K      Correspondence .....	61

**REGION 28 PLAN**  
**(As defined in)**  
**FCC Gen. Docket No. 87-112**

**FORWARD**

**Future Planning Requirements**

In order to provide realistic planning for public safety communications into the future, it is necessary to have sufficient contiguous radio spectrum at the onset of the planning process. There is a need for public safety contiguous virgin radio spectrum onto which an orderly migration over a long term may proceed. The amount of spectrum allocated need not require any more spectrum than that already allocated to public safety. Efficiency gained through contiguous spectrum and advanced technology will result in adequate public safety communications. In exchange for contiguous spectrum existing bands from 30 MHZ through newly allocated 800 MHZ could be returned for allocation to other radio services. Without sufficient spectrum available, this planning effort is relegated to merely distributing the recently identified public safety band at 800 MHZ. In urban areas, where frequency need and shortage are the greatest, these channels will be depleted before any type of significant planning process can make an inroad to the public safety communications problem. Future TV sharing has the capability of providing additional spectrum to the urban areas. However, this is yet another band that will further divide the interoperability of public safety. Additionally, this spectrum will be made available only within the major urban areas, leaving those areas just outside of the major urban areas without spectrum at 800 MHZ or TV sharing. If, at a minimum, this plan could consider 800 MHZ and TV sharing together, a more equitable and longer lasting plan could be developed. TV sharing would be used for limited coverage urban systems, while 800 MHZ would be used for wide area systems which are beyond the scope of TV sharing. Although allocation of spectrum in a piecemeal fashion is necessary to avert the present crisis, holding this allocation as a pretext of a comprehensive Public Safety communications plan is at best untenable and in reality unconscionable.

**REGION 28 PLAN**  
**(As defined in)**  
**FCC Gen. Docket No. 87-112**

**SCOPE**

**Introduction**

When the Federal Communications Commission announced the 800 MHz allocation of reserve radio frequencies to the Public Safety Services in July 1986, they mandated that a National Plan outlining the use of public safety frequencies must be in place before any agency would receive channels from this new allocation. In November 1986, a national meeting of all interested parties was called in Washington, D.C., with The Associated Public Safety Communications Officers, Inc., (APCO) as the convener. One of the major objectives of the meeting was to determine what the national plan should consist of. In December of 1986, the Commission (FCC) established the National Public Safety Planning Advisory Committee (NPSPAC) to involve parties interested in Public Safety in the planning effort. The date for submission of a final report from NPSPAC was established as September 30, 1987. The deadline was met. The recommendations contained in the Final Report were, for the most part, accepted by the Commission. The Final Report and Order, General Docket No 87-112, was adopted by the Commission, November 24, 1987. The National Plan established planning regions covering all parts of the United States, Puerto Rico, and the U.S. Virgin Islands. The Docket noted that no assignments would be made in the 821-824 and 866-869 MHz bands until a regional plan for each of the regions had been accepted by the Commission. Forty-eight regions were identified in the final docket. Region 28 was identified as the "New Jersey" Region. However, the area defined in the docket was in conflict with an area previously defined by an ad hoc regional planning committee, specifically, the Greater Delaware Valley Regional Planning Committee, which had been in existence for over one year. NPSPAC filed a "Petition for Partial Reconsideration and Expedited Action" with the F.C.C. requesting that Region 28 be modified to the Region identified by this Planning Committee.

**Purpose**

This Regional Plan was developed, as required by the Federal Communications Commission in Docket 87-112, to insure that maximum public benefit be derived from all radio communication systems used by eligibles that come under FCC rules for public safety radio services. Recognizing that the Tri-state area is currently experiencing shortages in the number of radio channels needed by many public safety agencies, the Plan was established with the objective of ensuring that unassigned frequencies would be distributed in an equitable fashion to those public safety agencies with the highest demonstrated need and that assigned frequencies were being utilized in the most efficient manner.

**Coordination with Adjacent Regions**

The importance of coordination of the Region 28 Plan with those of adjacent regions has been uppermost in the minds of the committee members throughout the planning process. Consequently, the Region 28 Committee is pleased to have members of this committee who also serve on Region 8, Region 20 and Region 36 Committees. The three APCO frequency coordinators for Delaware, New Jersey and Pennsylvania are also included on the Region 28 Committee. In addition, all of the surrounding regions have been provided with a copy of the plan and requested to provide their comments prior to filing of this plan. Positive comments were received from Region 8, Region 20 and Region 36 and no comments were received from Region 30 or Region 55 (see Appendix K).

**Flexibility of the Plan**

Although the plan concentrates on the current needs of the public safety community, there is recognition of the area's future requirements. To this extent the Plan may address such issues as UHF/TV sharing of frequencies, seeking a more restrictive definition of "public safety", modern loading standards, and other operational/technical initiatives. Furthermore, as conditions change, the Plan will be modified, when warranted, to reflect such changes.

**REGION 28 PLAN**  
**(As defined in)**  
**FCC Gen. Docket No. 87-112**

**AUTHORITY**

**Regional Planning Committee**

The Federal Communications Commission, in its November 24, 1987 Report and Order applicable to Docket 87-112 noted:

The Associated Public-Safety Officers, Inc. (APCO), acting under its frequency coordination responsibilities, will be responsible for convening a meeting to initiate the planning process in each region. For each region, APCO should appoint a local convener who will be responsible for organizing and publicizing the first planning meeting... The convener should set a date for the initial planning meeting, allowing at least 60 days for appropriate public notifications. Parties interested in participating in the regional planning process should contact the appropriate convener.

This was accomplished in Region 28, with the initial meeting being held on April 26, 1988, in the Montgomery County Fire Academy, Conshohocken, Pennsylvania. At that meeting, a board-of-officers was elected, rules of order established, and certain task chairpersons appointed. All attendants were invited to take part in the development of this regional plan.

Prior to this FCC mandated meeting, an ad hoc committee, similar to the committee which had been formed in the New York Metropolitan region, was in existence for the area now defined as Region 28. The committee consisted of representatives of the states of Delaware, New Jersey and Pennsylvania. Rather than start from square one, the trials and tribulations suffered by these pioneer groups were taken advantage of by the new Region 28 Planning Committee. It should come as no surprise to the reader of both plans, that plagiarism is apparent. However, as with real life day-to-day interoperability, cooperation is a necessity for survival in the public safety environment. The work of the Region 8 and 28 ad hoc committees served as a foundation for this final plan.

**National Interrelationships**

The Regional Plan is in conformity with the National Plan. If there is a conflict between the two plans, the National Plan will govern. It is expected that Regional Plans for other areas in the country may differ from the Plan for this area due to dissimilar situations. By officially sanctioning the Plan the FCC agrees to its conformity to the National Plan. Nothing in the Plan interferes with FCC for frequency coordination in the Private Land Mobile Service but rather provides procedures that are the consensus of the Public Safety Radio Services user agencies in the Region. If there is a perceived conflict, the judgment of the FCC will prevail.

**Federal Interoperability**

Interoperability between Federal, State and Local Government during both daily and disaster operations will primarily take place on the five common channels identified in the National Plan. Additionally, through the use of S-160 or equivalent agreements, a licensee may permit Federal use of a non-Federal communication system. Such use, on other than the five identified common channels, is to be in full compliance with FCC requirements for government use of non-government frequencies (Title 47 CFR section 2.103). It is permissible for a sub-Federal licensee to increase channel requirements to account for up to a 2% increase in mobile units, provided that written documentation from Federal agencies supports at least that number of increased units.

### **Regional Plan Update Committee**

With the approval of the Regional Planning Committee, the Chairman shall appoint a Regional Plan Update Committee (RPUC). This committee will remain in place to recommend changes in the Regional Plan to the FCC and provide a mechanism for interregional resolution of problems which arise.

The standing membership of the RPUC shall consist of each APCO designated local frequency advisor for the Regional Planning Area (3 members); plus one each representing the State of Delaware, New Jersey, Pennsylvania (3 members); three members representing Public Safety Radio Services and two members representing the Special Emergency Radio Service (5 members), for a total of 11 members. In no case shall any radio service have a majority membership.

The following rules and procedures shall be established:

- o elect a Chairperson
- o develop a mechanism to fill committee vacancies
- o with FCC approval modify committee membership
- o set response time to process received frequency applications
- o publish meeting schedule
- o determine committee voting standards
- o develop applicant appeal process
- o audit implementation of those systems subject to the Plan
- o enact policy for frequency give-backs
- o maintain coordination with neighboring regional committees
- o participate in the annual meeting of all regional committees
- o promulgate other rules and procedures as required

It should be noted that the FCC will not fund any expenses incurred by the Regional Plan Update Committee.

**REGION 28 PLAN**  
**(As defined in)**  
**FCC Gen. Docket No. 87-112**

**SPECTRUM UTILIZATION**

This portion of the Plan provides a basis for proper spectrum utilization. Its purpose is to guide the Committee in their task of evaluating the implementation of radio communication systems within the Region.

**Region Defined**

As mentioned earlier, the Federal Communications Commission's Report and Order, adopted November 24, 1988 (applicable to General Docket No. 87-112), forty-eight regions were identified. Region 28 was initially identified as New Jersey (except for counties which were included in NEW YORK-METROPOLITAN Region 8 Plan), Pennsylvania (the counties of Bucks, Chester, Montgomery and Philadelphia), and the State of Delaware. This of course was in conflict with that area which had been identified by the then in place ad hoc committee (The Greater Delaware Valley Regional Planning Committee). A Petition for Partial Reconsideration and Expedited Action was submitted to the FCC requesting that Region 28 be redefined so as to conform with the regional boundaries established by the then in place ad hoc committees. The FCC granted relief. Region 28, as now defined by the FCC is the entire State of Delaware, specifically the counties of New Castle, Kent and Sussex. The southern portion of the State of New Jersey, namely that area south of a division line that follows the northern border of Burlington County and the southern border of Monmouth County. Specifically, the counties of Atlantic, Burlington, Camden, Cape May, Cumberland, Gloucester, Ocean and Salem. Pennsylvania is divided into two regions. The West Branch Susquehanna River is basically the dividing line. Specifically the counties of Bradford, Berks, Bucks, Carbon, Chester, Columbia, Dauphin, Delaware, Montgomery, Philadelphia, Lehigh, Northampton, Lackawanna, Lancaster, Lebanon, Luzerne, Lycoming, Monroe, Montour, Northumberland, Pike, Schuylkill, Sullivan, Susquehanna, Tioga, Wayne, Wyoming and York.

**Usage Guidelines**

All systems operating in the FCC Region 28 planning area having five or more channels will be required to be trunked. Those systems having four or less channels may be conventional.

The FCC in its Report and Order states, "Exceptions will be permitted only when a substantial showing is made that alternative technology would be at least as efficient as trunking or that trunking would not meet operational requirements. Exceptions will not be granted routinely. Strong evidence showing why trunking is unacceptable must be presented in support of any request for exception."

Systems of four or less channels operating in the conventional mode who do not meet FCC loading standards will be required to share the frequency on a non-exclusive basis.

Public safety communications at a state level, as it impacts the Region, will be reviewed by the Committee. Statewide public safety agencies will submit their communications plans for impact approval if they utilize communications systems within the Region and those portions of such systems must be compatible with the Regional Plan.

The next level of communication coverage will be county/multiple municipality area. Those systems that are designed to provide area communication coverage must demonstrate their need to require such wide area coverage. Communication coverage beyond the bounds of a jurisdictional area of concern cannot be tolerated unless it is critical to the protection of life and property. If the 800 MHZ trunked radio technology is utilized, the system design must include as many county/multiple municipality government public safety radio users as can be managed technically.

The county/multiple municipality agency or agencies, depending upon systems loading and the need for multiple systems within an area, must provide inter-communications between area wide systems. In a multi-agency environment, a lead agency using 800 MHZ spectrum must implement the Common Channels in this band as mandated by the National Plan. Such implementation must be reviewed and approved by the Committee.

Municipal terminology in each state may be different. In order to provide a title for the next level of communications the term "Township" is used to define the level below county wide. Township communications for public safety purposes must provide only the communications needed within its boundaries. However, if the total number of radios in service does not reach minimum loading criteria for a trunked

system, the township must consider utilizing the next higher system level if 800 MHz trunked radio is available in the area. As those higher level systems reach capacity, the smaller system communicators in the public safety service must then consider uniting their communications efforts to formulate one large system or forfeit use of the limited 800 MHz spectrum.

Where smaller conventional 800 MHz needs are requested, those frequencies to be utilized must not interfere with the region's trunked systems. The 800 MHz trunked radio system is to be considered the higher technology at this time and in greater compliance with FCC guidelines. The amount of interference that can be tolerated depends on the service affected. Protection of life and property shall receive the highest priority. Disruptive interference with communications involved in these services in all areas shall not be tolerated. Any co-channel interference within an authorized area of coverage will be examined on a case-by-case basis with 12db below system strength to be considered the maximum tolerable nuisance level.

A requesting applicant for radio communications in the 800 MHz public safety services in the Region will be required to provide loading criteria information for its proposed system. The provisions of this regional plan must be used as a guide for establishing any new systems. Strict adherence to limiting area of coverage to the boundaries of the applicant's jurisdiction must be observed. Overlap or extended coverage must be minimized even where systems utilizing 800 MHz trunked radio are proposing to intermix systems for cooperative and/or mutual aid purposes.

Antenna heights are to be limited to provide only the necessary coverage for a system. When antenna locations are restricted to only the "high ground", transmitter outputs and special antenna patterns must be employed to produce the necessary coverage with the proper amount of ERP. All necessary precautions will be taken to gain maximum reuse of the limited 800 MHz spectrum.

As part of this plan, distances between transmitters for co-channel reuse will not be held to seventy (70) mile separation. Separation of co-channel transmitters will be determined by the coverage needs of the applicant, natural barriers for separation, antenna patterning and limited ERP's where possible. System tests and/or propagation studies should also be provided to establish minimum distances for separation

### **Reassignment of Frequencies**

It is anticipated that, in all but the most unusual cases, frequencies presently utilized by a licensee will be turned back for reassignment. The FCC authorized frequency coordinators will be responsible for assignment of the channels to the various agencies awaiting channels in the lower frequency bands. Normal coordination procedures will be followed with these take-back channels except that the applicant evaluation criteria established in the National plan and further defined in this Regional plan is to be considered by the recognized frequency coordinator. In such cases where specific channels are required by numerous applicants, the applicant evaluation matrix will be utilized. In all cases, area of coverage criteria and channel loading criteria will be applied, except upon unique circumstances after receiving a waiver from the Regional Planning Committee. It is not consistent with the goals and objectives of this Region to permit the direct reassignment of radio frequencies between agencies. All frequencies are to be returned to their respective pools to be assigned to the most public beneficial use. Similarly, an agency should not be able to "farm down" frequencies to other services within their political structure simply to take advantage of surplus equipment. The need for communications by such an agency may be outweighed by the needs of another political subdivision.

This Regional Plan will consider for planning purposes the communication needs of all current eligibles under the FCC's Public Safety Radio Services and Special Emergency Radio Services. Additionally, this Regional Plan will consider the communication needs of those public safety service associated operations as the Regional Planning Committee may deem necessary and desirable for Local area needs.

### **SUPPLEMENT TO THE APPLICATION FORM**

With each application form (modified APCO Form FDR2) submitted directly to the local frequency advisor, the applicant shall also supply the following supplemental information:

- \* Details of engineering survey showing radio coverage will not exceed applicants minimum requirements.
- \* Explain how system will be used to communicate with other services in other bands.
- \* Explain any budget commitment that has been made for the proposed system.
- \* Explain how system will interface with long distant radio communications such as amateur radio, satellite communications, and/or long-range emergency preparedness communications systems.

- \* Statement of need for installing a new 800 MHz system.
- \* Explain and certify that the applicant's agency will comply the common channel implementation requirements.
- \* Detailed information as to the frequencies presently licensed to the applicant. Which frequencies will be turned back and which will be retained. Justification for any retained frequencies.

**REGION 28 PLAN**  
**(As defined in)**  
**FCC Gen. Docket No. 87-112**

**COMMUNICATIONS REQUIREMENTS**

**Common Channel Implementation**

It shall be the responsibility of each agency to provide base station equipment in compliance with the National Plan on the "Calling Channel".

**Areas of Operation**

The total area of operation shall encompass the Region, as defined elsewhere in the Plan, and shall extend outward to include the total system area of any system of which any portion thereof falls within the Region.

**Operation of the Common Channels**

Normally, the five interoperable channels are to be used only for activities requiring inter-communications between agencies not sharing any other compatible communications system. Interoperable channels are not to be used by any level agency for daily operations or for interagency communications not requiring interoperability. In major emergency situations, one or more tactical channels may be assigned by the primary dispatch center to alleviate temporary communications loading problems. Police, Fire and providers of Basic and Advanced Life support services will be the primary using agencies. Other services provided in their Public Safety Radio Service may also participate to the extent required to insure the safety of the public. School buses or other approved transportation facilities shall be included into interoperability only to the extent that such vehicles are enrolled in an emergency evacuation plan under the auspices of an emergency management agency.

**Sub Regions**

The Region shall be broken down into sub-regions that conform with state political boundaries. Each sub-region, defined as a county or a group of counties, shall establish at least one mobile relay operation for the Calling Channel and the tactical channels assigned. Each dispatch center shall be responsible for the coordination with adjacent dispatch centers as well as with other central points in the region, if required. Any agency operating independently of the county plan (sub-region) shall be required to establish a radio control point on the calling and tactical channel in its area.

**OPERATING PROCEDURES**

**Vocabulary**

On all common channels plain ENGLISH will be used at all times, and the use of unfamiliar terms, phrases or codes will not be allowed. Users will be coming from varied backgrounds and disciplines each having its own language. Any attempt to introduce a new code would only confuse the issue and cause confusion and possibly even rejection of the interoperability concept.

**Calling Channel (ICALL)**

The calling channel shall be used to contact other users in the Region that can render assistance at an incident. This channel shall not be utilized as an ongoing working channel. Once contact is made between agencies, an agreed upon tactical or mutual aid channel shall be used for continued communications.

**Tactical Channels (ITAC 1 - ITAC 4)**

These channels are reserved for use by those agencies involved in interagency communications. Incidents requiring multi-agency participation will utilize these channels as directed by the control agency assuming responsibility for an incident or area of concern. These tactical channels 1 through 4 are allocated to each sub-region as primary and secondary, such that co-channel interference will be minimized. The following is a schedule of tactical channel assignments for each of the sub-regions.

## Schedule of Tactical Channel Assignments

#	COUNTY	ST	ITAC CHANNEL PRI	ITAC CHANNEL SEC	#	COUNTY	ST	ITAC CHANNEL PRI	ITAC CHANNEL SEC
1	Berks	PA	1	4	21	Pike	PA	2	3
2	Bradford	PA	4	1	22	Schuykill	PA	3	2
3	Bucks	PA	4	1	23	Sullivan	PA	1	4
4	Carbon	PA	4	1	24	Susquehanna	PA	2	3
5	Chester	PA	4	1	25	Tioga	PA	3	2
6	Columbia	PA	4	1	26	Wayne	PA	4	1
7	Dauphin	PA	4	1	27	Wyoming	PA	3	2
8	Delaware	PA	2	3	28	York	PA	1	4
9	Lackawanna	PA	1	4	29	Atlantic	NJ	1	4
10	Lancaster	PA	3	2	30	Burlington	NJ	2	3
11	Lebanon	PA	2	3	31	Camden	NJ	4	1
12	Lehigh	PA	2	3	32	Cape May	NJ	2	3
13	Luzerne	PA	2	3	32	Cumberland	NJ	4	1
14	Lycoming	PA	2	3	34	Gloucester	NJ	2	3
15	Monroe	PA	3	2	35	Ocean	NJ	3	2
16	Montgomery	PA	3	2	36	Salem	NJ	3	2
17	Montour	PA	3	2	37	Kent	DE	1	4
18	Northampton	PA	1	4	38	New Castle	DE	3	2
19	Northumberland	PA	1	4	39	Sussex	DE	4	1
20	Philadelphia	PA	1	4					

## **Network Operation Method**

A network will be established on the calling channel, ICALL. This network will be wide area to cover large sections of the Region. Multiple networks may be required to fully cover the outlying areas of the region. Multi-state coverage networks will be monitored by a selected agency in each state, i.e., State Police Communications. Communications systems on ITAC 1 - ITAC 4 will be implemented by agencies who place a trunking system on line. Every geographic section of the Region is intended to be covered by at least one of the working channels. Mobile relays on ITAC 1 - ITAC 4 will be on a limited coverage design to permit reuse of the channel several times within the Region and in adjacent regions.

## **Encryption Standards**

The use of encryption in the Region #28 Plan is encouraged for those agencies, that as part of their operation have need to conduct covert operations that require some assurance of communications security. The Plan recommends encryption techniques that provide high levels of communication security as well as a high level of voice recognition. It is required that systems operation within the Region that utilize digital encryption algorithms transmit in a digital format with the use of an analog to digital conversion technique having a bit rate not to exceed that which will fit within a 25 KHz channel. Agencies that interoperate with Federal agencies in covert operations will be required to use secure communications that comply with standards set by the National Security Agency. Standards vary according to classifications and are based on the sensitivity and nature of the information to be exchanged. Many of the agencies, such as the FBI, US Customs, DEA, and the Coast Guard, that interoperate with State and Local agencies are required to use encryption which meets FIP-S42 data encryption standard. To provide for encryption at a minimum, all communication system infrastructures should be digital capable, that is capable of passing encrypted digital communications through the system. A digital capable fixed end will allow State, Local, and Federal agencies to use their subscriber units on any of these systems in the encrypted mode independently, or by sharing a common key, to work with each other securely. Further, this digital capability will accommodate those agencies with S160 agreements and will provide for anticipated future interoperability requirements. The nature of communications on the 5 common channel pairs to support the National Mutual Aid system is designated for tactical operations, disaster and emergency management, as well as local and regional interoperability. The ability to operate securely on these channels would both protect and enhance these operations. It is evident that the capability of these channels to support secure communications is also strongly recommended.

## **Use of Long Range Communications**

During incidents of major proportions where public safety requirements might include the need for long range communications in and out of a disaster area, alternate radio communications plans are to be addressed by each primary Public Safety Dispatch Center in the Region. As a minimum, the agencies operating such centers shall integrate the appropriate interface either electrically or through the dispatcher to the five national channels as a minimum. Such long distance radio communications might be amateur radio operations, satellite communications and/or long range emergency preparedness communications systems such as State Police radios. These should be incorporated as part of the communications plans of those agencies. They then could provide the means to communicate outside the area for themselves and the smaller agencies who may need assistance. Instances as addressed in the National Public Safety Planning Advisory Committee's Plan such as earthquakes, hurricanes, floods, widespread forest fires or nuclear reactor problems could be a cause for such long range communication needs.

## **Use of Cellular Telephone**

The incorporation of public switched telephone network (PSTN) in a planned radio system is a vital part of public safety communications. To provide this capability, Region 28 strongly recommends the use of cellular telephones in those areas where (and when) cellular service is available. In addition, this regional plan encourages the use of dispatcher intervention for telephone interconnection to the planned radio system. For routine, day-to-day operations, the use of automatic telephone interconnects is not recommended by Region 28. These interconnects will tie up vital air time where the use of cellular telephones might not impact so dramatically. However, in exceptional circumstances (such as the cellular system becomes inoperable due to loading or equipment malfunction, or in those areas where there is no cellular telephone service) automatic telephone interconnects would provide secondary access to the PSTN.

## **IMPLEMENTATION AND PROCEDURES**

### **Notification**

All interested parties were invited to participate in the development of the Regional Plan. This notification was accomplished by the FCC issuing a Public Notice and by the "convener" directly notifying organizations representing eligibles. In addition, the mobile communications print media were contacted by the "convener" and made aware of the Committee's formulation. Also notified were the appropriate state government contacts in each of the three states of Delaware, New Jersey, and Pennsylvania. See "Appendix H"

### **Evaluation Sub-Committee**

The Evaluation Sub-Committee shall consist of the Chairman of the Region 28 committee and the Task Group Facilitators for the Region 28 Committee. In addition, the APCO Frequency Advisors for Delaware, New Jersey, and Pennsylvania shall serve as members of this sub-committee.

### **Frequency Allocation Process**

The attached flow chart, (Appendix A) entitled "800 MHZ Frequency Allocation Process", shows the sequence of events that will be followed by The Region #28 Planning Committee in the process of allocating the six megahertz of 800 MHZ spectrum. This process follows the guidelines established under the National Plan for Public Safety Spectrum Relief. The Region #28 Plan incorporates a filing window concept which will provide for the evaluation of all applications for the available spectrum at the same time. The evaluation matrix process is as follows:

Upon approval of the Region #28 Plan by the Federal Communications Commission (FCC) the six megahertz of spectrum is made available for allocation. The allocation is placed in the frequency pool (Block #1). If frequencies are available in the pool (a second iteration of the evaluation matrix could occur if all frequencies are not allocated on the first iteration) a window opening announcement is made (Block #2). The window period will be two calendar months or 60 days, (Block #3 thru Block #4) with early or late applications rejected (Block #5). Those applications which are received during the window period are reviewed by the local frequency advisor of the respective state from which the application originated (Block #6). The local advisor will determine if the application is in compliance with state plans, if a state plan exists (Block #7). An application that is not in compliance will be returned to the applicant with an explanation of changes required to be compliant. Having complied with state plans and provided a needs assessment (Block 9), the Evaluation Sub-Committee will apply the evaluation Matrix (Block 10). The Evaluation Sub-Committee is defined as: two members (minimum) from each State of the Region #28 Planning Committee

The implementation of the evaluation matrix will result in the award of a score for each application. That score is the total of the points awarded in seven categories, with a maximum possible score of 1000 points, as outlined in Appendix B. The seven categories are as follows:

## EVALUATION MATRIX

**I. SERVICE (Block #11)** - maximum score 350 points. Each of the eligible services has a predetermined point value. That point value ranging from 0 to 35 is multiplied by ten (10) to determine the score for the Service Category. An applicant with multiple services will be scored on the basis of the percentage that each service represents of the total system. That is, a system which is 50 percent police and 50 percent school administration (local government) would be awarded the total of 50 percent of the point value for police plus 50 percent of the point value for school administration.

**II. INTEROPERABILITY (Block #12)** - maximum score 100 points. The application is scored on the degree of interoperability that is demonstrated with a range of points from 0 to 100. This category does not rate the application on the inclusion of the mandated five common channels for interoperability. This category does rate the application on his proposed ability to communicate with different levels of government and services during times of emergency.

**III. LOADING (Block #13)** - maximum score 200 points. Those applicants that have demonstrated that they are part of a cooperative, multi organization system will be scored on a range of 0 to 150 points depending upon the extent of the cooperative system. An expansion of an existing 800 MHz system will be scored on a range of 0 to 50 points, depending upon the degree of expansion. A system could be an expansion of an existing 800 MHz system and a cooperative system as well and as a result receive the combined point values for these two sub-categories for a maximum value of 200 points.

**IV. SPECTRUM EFFICIENT TECHNOLOGY (Block #14)** - maximum score 50 points. This category scores the applicant on the degree of spectrum efficient technology that the system demonstrates. A point value range of 0 to 50 points can be awarded for this category. A trunked system would be considered a spectrum efficient technology as well as any technological systems feature which is designed to enhance the efficiency of the system and provide for the efficient use of spectrum.

**V. SYSTEMS IMPLEMENTATION FACTORS (Block #15)** - maximum score 100 points. This category scores the applicant on two factors, budgetary commitment and planning completeness. The degree of budgetary commitment is scored on a range of 0 to 50 points. An applicant that demonstrates a high degree of commitment in funding the proposed system will receive the higher score. Each applicant will be scored on the degree of planning completeness with a range of scoring from 0 to 50 points. Applicants will be required to submit a time table for the implementation of the communications system or systems.

**VI. GEOGRAPHIC EFFICIENCY (Block #16)** - Maximum point value of 100 points. Each applicant will be scored on the level of geographic efficiency based on the following factors; total number of radio units (including control stations), the number of frequency pairs requested, and the square miles covered. For a strip or ribbon system the square mile figure will be replaced by the length in miles of the strip or ribbon.

**VII. GIVEBACKS (Block #17)** - maximum score 100 points. The applicant is scored in two sub-categories, each having a point range of 0 to 50; the number of channels given back and the extent of availability of those channels to others. The greater the number of channels given back, the higher the score. The greater the level of availability of the give-backs, the higher the score will be in this sub-category.

Points are totaled for each application (Block #18) and the applications are prioritized by the Evaluation Sub-Committee (Block #19). The frequency pool is allocated (Block #20) and the Regional Plan is updated. The plan is then sent to the FCC for review and approval as outlined in the Report and Order Docket 87-112 (Block #21). Upon approval of the plan by the FCC, the applicant will be notified and the applications submitted to APCO for coordination (block 22), after which, the FCC would grant the license to the applicant (Block #23).

The system implementation is monitored by the Local Frequency Advisor who determines if progress is

made on the implementation of the system (Block #24). If progress is made (Block #25) the system is ultimately implemented (Block #26). If progress is not made the licensee is warned of the consequences of his lack of progress (Block #27). The Local Frequency Advisor continues to monitor progress on the implementation of the system (Block #28). If the continued monitoring indicates that progress is still not being made the licensee is notified of pending action to withdraw the license (Block #29). The notified licensee can appeal this action (Block #30) or can allow the license to be withdrawn (Block #31). If the allocated frequencies are withdrawn they are added back to the frequency pool (Block #32) and the process starts a second iteration at Block #1.

### **Implementation Schedules (Slow Growth)<sup>1</sup>**

The majority of eligible public safety organizations are either of State and Local government, or else are subject to governmental regulation. The nature of governmental planning and budgeting processes, combined with difficult revenue constraints, prohibits most eligibles from implementing newer technology systems in the normal time required by **FCC Rules**<sup>2</sup> (8 months for construction of conventional stations, 12 months for trunked stations). In most cases, public safety systems will require multi-year phased-implementation schedules requiring three to five times as long to construct as private or commercial systems. Regional, wide-area, and statewide systems will require even longer periods to construct.

In view of these known situations, this Region Plan establishes an extended implementation schedule ("slow growth") in accordance with **FCC Rules**<sup>3</sup> which is available to all eligible applicants, if requested by stating "SLOW GROWTH" on the license application.

A "slow growth" schedule will allow up to three years for completion of station construction. Regardless of station construction time however, the FCC five-year channel loading requirement (of mobiles, portables and RF control stations) is maintained by this Region Plan.

Applicants who clearly request "SLOW GROWTH" on their license application are not required to submit the specific items of "slow growth" justification otherwise required by FCC Rules.

Applicants who propose a station construction schedule which is longer than the three-year "slow growth" schedule, or a channel loading schedule (for mobiles, portables, and RF control stations) beyond five years, are required to submit a Request for Waiver for such additional extensions of time in accordance with FCC Rules.

### **Appeal Process**

Throughout the frequency allocation process applicants are given opportunities to appeal decisions which have caused rejection of their application. The appeal process has two levels; APCO and the FCC. An applicant who decides to appeal a rejected application should initiate that appeal immediately upon notification of rejection. In the event that an appeal reaches the second level, the FCC, their decision will be final and binding upon all parties.

---

1 This section of the Plan was accomplished through an amendment approved by the FCC.

2 See FCC Rules and Regulations 90.155 (a) and 90.631 (e)

3 See FCC Rules and Regulations 90.629, 90.631 and 90.633.

**REGION 28 PLAN**  
**(As defined in)**  
**FCC Gen. Docket No. 87-112**

**EPILOGUE**

The development of an operational plan providing for frequency assignment within Region 28 has been achieved with much effort, expense and time by the parties of interest. The formulating committee has had the advantage of a wide range of individual representation and eligible applicants participating during the process. The objective, upon which it has been devised, recognizes current and future public safety needs including the interoperability among users (for both the new allocation and for those presently using 806/821 & 851/866 MHz Band). The plan further recognizes the importance and proper use of the common mutual aid channels also established by the allocation.

Of great importance was the need to insure that the plan be flexible enough to provide for expansion of systems. System modifications must not be unduly restricted in order to employ evolving applications and technologies or to provide voice/data encryption. The interdiction of high speed data transmission from and to mobile units as well as between base stations and links, could offer some highly efficient alternatives to traditional technologies and will serve both inter and intra disciplinary modes of operation.

No matter how proficient, our plan is not without its caveats. More than likely any deficiency will be caused not by ignorance but in the absence of a more convincing argument supporting another alternative. An issue requiring refinement will be the obvious interaction of coordination required between Regions. Frequency demands near borders will surely generate conflicts between Committee assignment criteria. In the case of Region 28, the Commonwealth of Pennsylvania is a divided Region which conceivably could require as many as eight (8) Regional concurrences for the assignment of a single channel to be used statewide. New Jersey, also in Region 28, faces stiff competition for resources with an adjacent major metropolitan area.

The cumulative effect of this added coordination activity will impose strain upon the system and will have a profound effect upon the resources any one Region may be able to assign. Such predictable limitations upon the frequencies influenced by interregional coordination is not a new problem.

Preliminary restrictions could very well deny the use of better than half of the frequency table in cases where large metropolitan statistical areas overlap or are adjacent.

The establishment of this plan under which allocations will be made, require a much greater emphasis upon short range and long range telecommunications planning. Because the Federal Communications Commission has indicated that it intends to grant waivers in cases which are fully justifiable, the nature of waivers will soon be accepted as reasonably assured and become practice. By assuming that greater emphasis be placed in awarding allocation consideration to both funding and planning criteria, many of these waivers may not be necessary and allowing good long range planning to have a higher credibility.

Likewise, it may be necessary for Committees to engage in compliant inspections in order to assure that its engineering criteria have not been compromised. As a matter of routine, such inspections if sanctioned by the FCC for informational purposes, could preserve the assignment integrity of allocations. On the other hand, this concept is not without basis in current practice and could very well be a controversial issue.

For almost every assignment criteria proposed, an adjustment will more than likely need to be made. Planning groups wishing to conclude their work in order to provide an approved allocation rationale must also provide for suitable policy revisions should the need arise.

The issue of engineering standards in signaling and equipment systems has clearly been resolved in the record but remains as an issue of controversy. The long range effect of no set standard will be hard to predict. Yet it may be possible for interface software to solve the manufacturing incompatibility problem

in the future with imposition of such standards. In addition, manufacturers who develop equipment and systems with ease of frequency agility can maximize the effectiveness of any mistakenly assigned frequencies or whole scale readjustment which may be required in an on going program. Such capability would be very desirable and definitely enhance the Frequency Coordinating Group's task of maximizing systems.

Finally, the committee encourages the development of user groups to resolve the many economies of scale, and facility sharing arrangements possible in the establishment of future systems. Perhaps legislation could enhance the attractiveness of such sharing by protecting users from unsuspected liabilities characteristic of such participation.

The potential for the creative use of this resource and the effective use of the reserve are at complete odds. If current resources are totally maximized then reserves may be slow to be assigned or assigned elsewhere. If on the other hand Committees are liberal in their assignments, the reserves may be reached far sooner than predicted. This self-defeating conflict of interest will play a part in the effectiveness of all planning and coordination group of activities. The FCC should provide some assurance now that reserves will be provided so that initial efforts will not be undermined.

\*\*\* END \*\*\*

**REGION 28 PLAN**  
**(As defined in)**  
**FCC Gen. Docket No. 87-112**

**APPENDICES**

APPENDIX A	Evaluation matrix
APPENDIX B	Point Assignment Criteria
APPENDIX C	Population in Regional Planning Area
APPENDIX D	Population Density in Regional Planning Area
APPENDIX E	Regional Planning Area Map
APPENDIX F	F1 Frequency Assignment Methodology F2-6 Current Channel Assignment Plan F7 Pending Filing Window Amendment
APPENDIX G	Committee Members, Task Groups and Subcommittees
APPENDIX H	Convening Meeting Notification List
APPENDIX I	Committee Rules
APPENDIX J	Participating Agencies
APPENDIX K	Correspondence

800 MHZ FREQUENCY ALLOCATION PROCESS

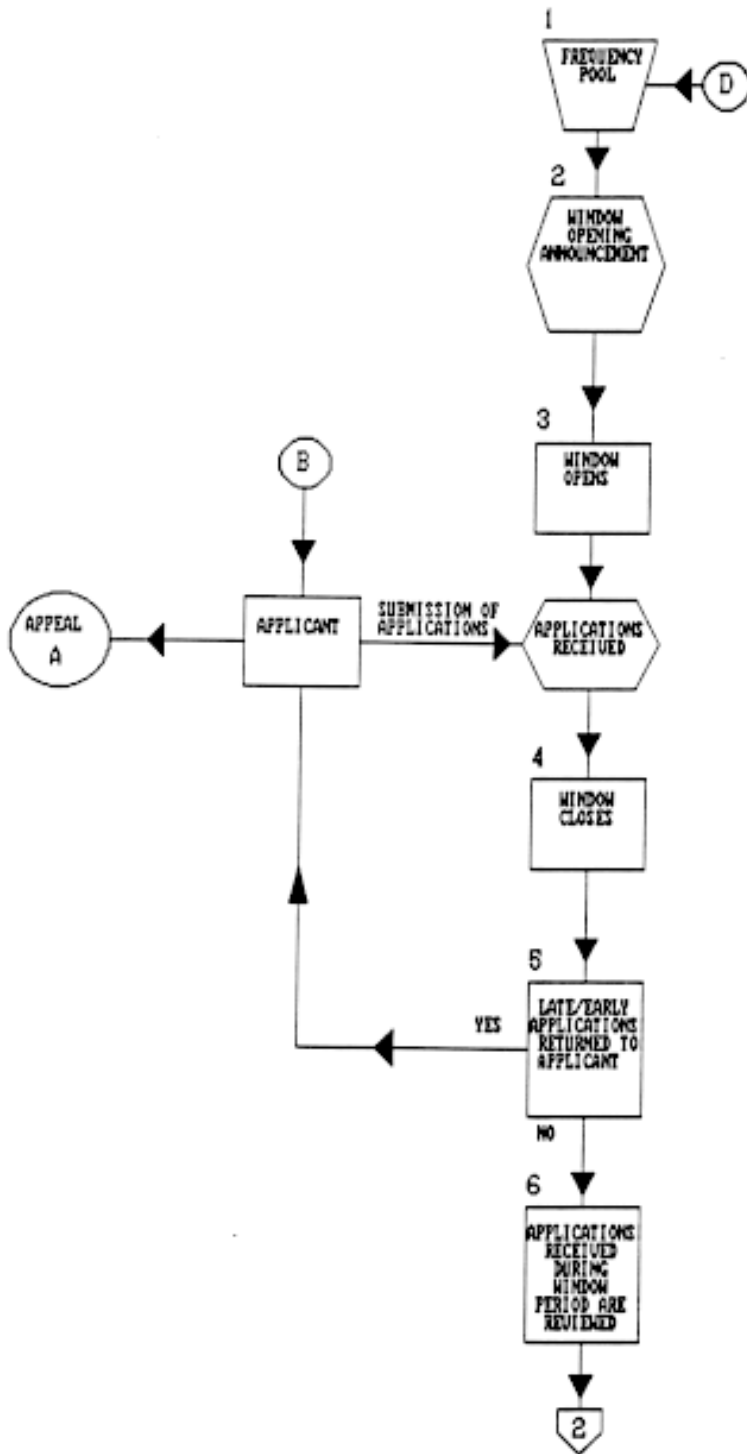

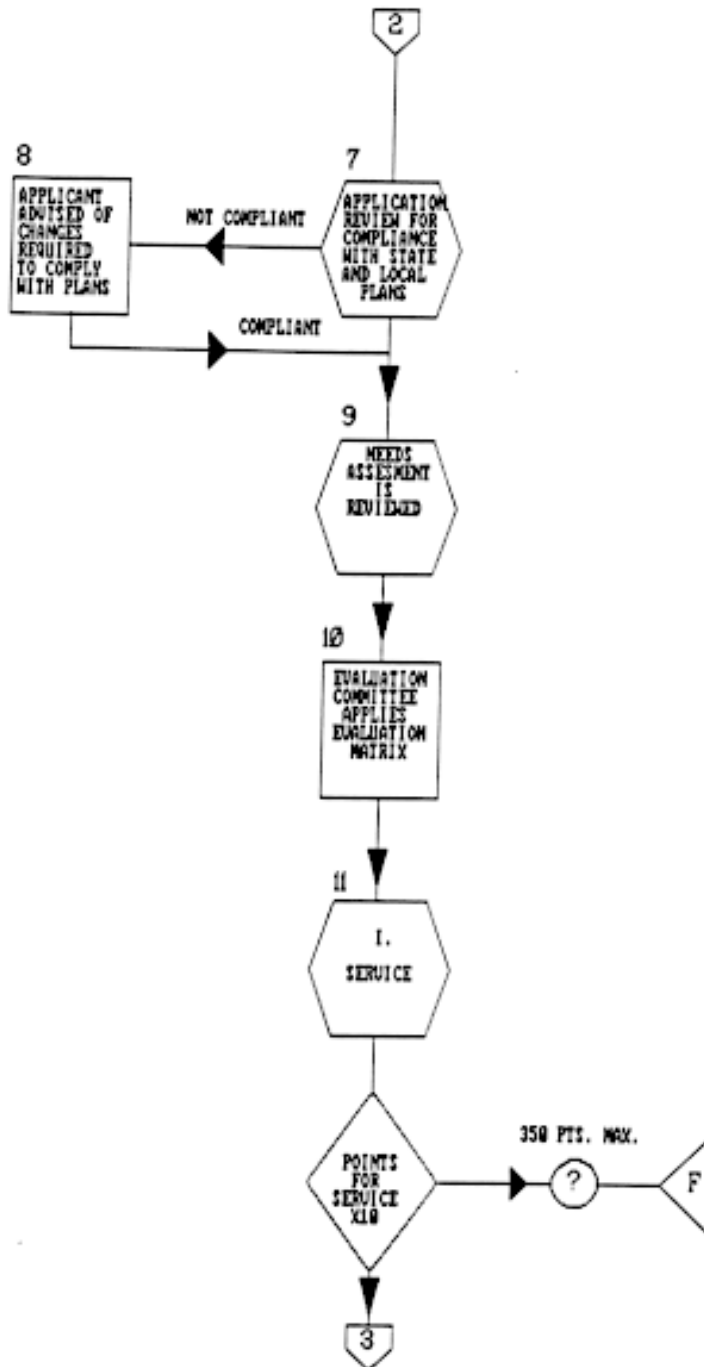

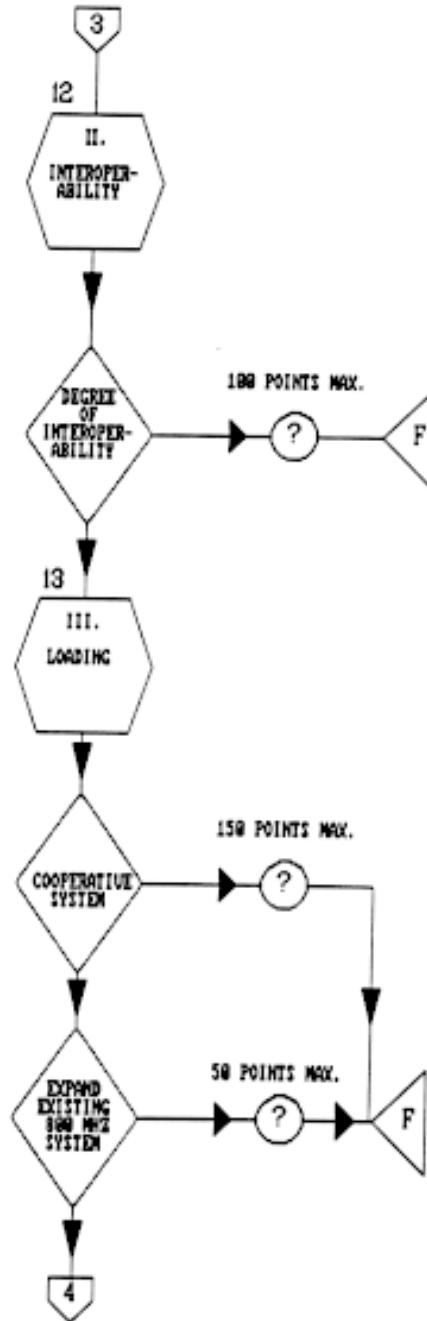

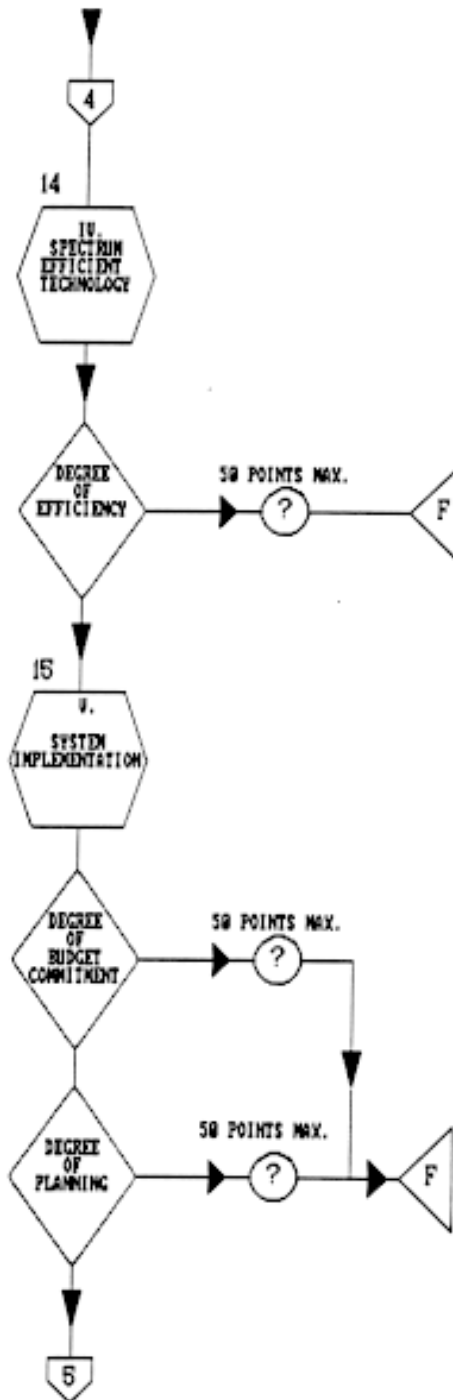

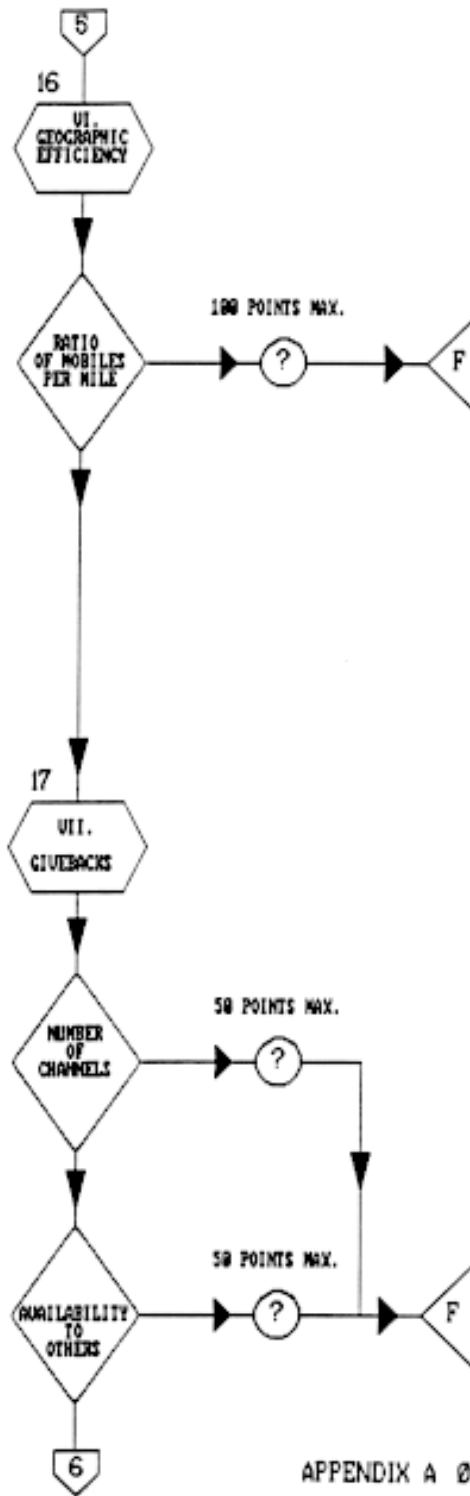

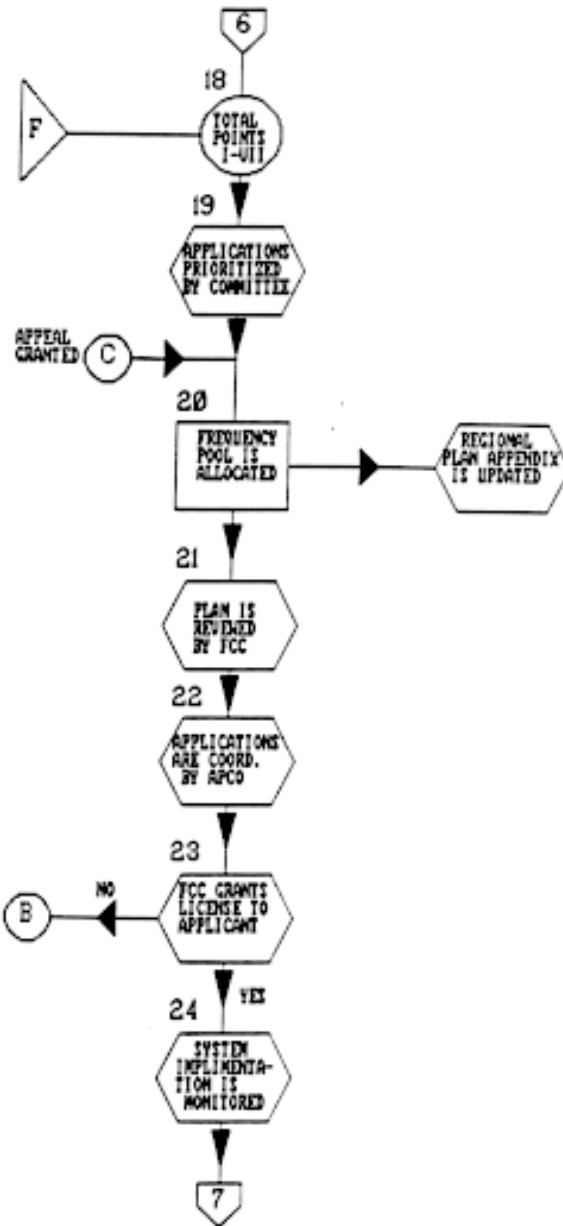

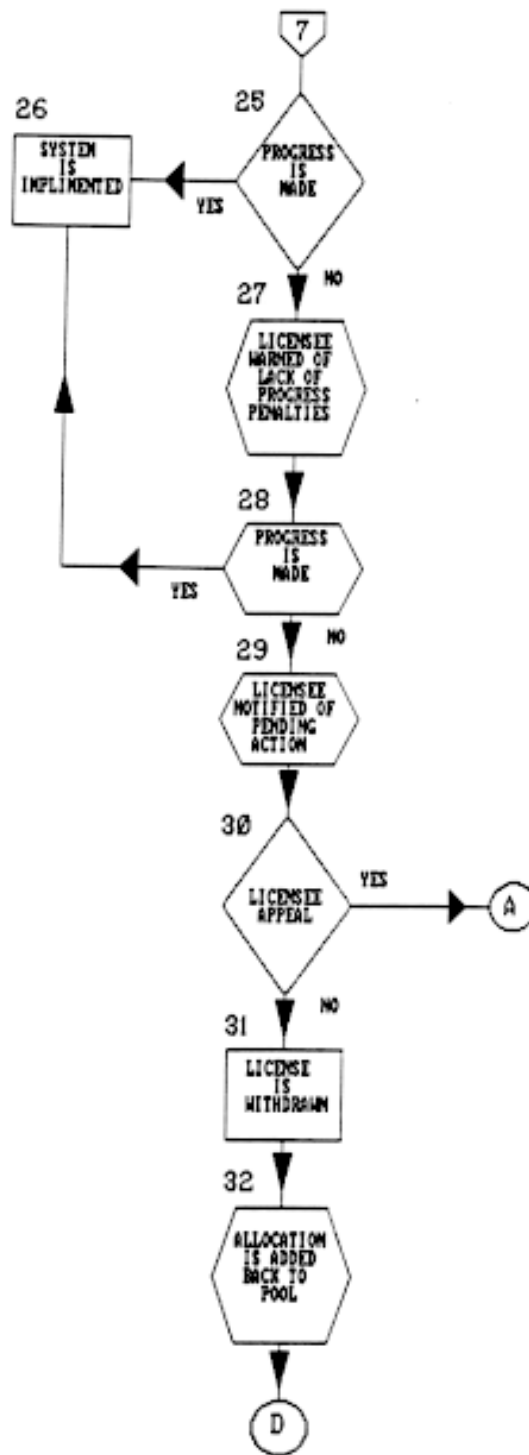

APPEAL PROCESS

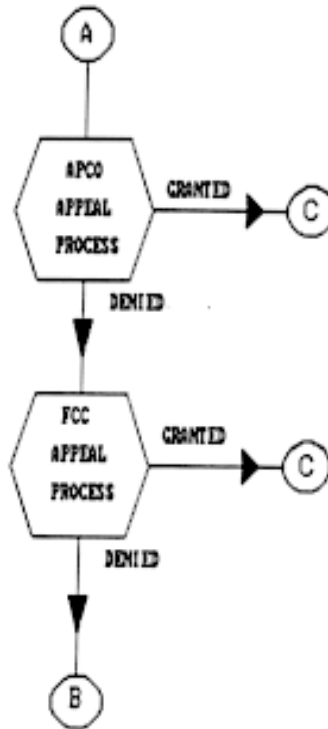

PART 2:

Expansion to an existing system is awarded bonus points based on the minimum number of channels requested with the maximum loading at 10 points per channel, up to five channels:

NUMBER OF CHANNELS:	POTENTIAL UNIT LOADING:	NUMBER OF BONUS POINTS:
1	100	50
2	200	40
3	300	30
4	400	20
5 OR MORE	500 PLUS	10

CATEGORY IV. SPECTRUM EFFICIENT TECHNOLOGY

Applications are awarded points based on the type of technology utilized at 5 points per channel for conventional systems and 10 points per channel for trunking systems and is considered on bases of spectrum which offers maximum loading with minimum channels:

NUMBER OF CHANNELS:	POINTS FOR CONVENTIONAL:	POINTS FOR TRUNKING:
1	25	50
2	20	40
3	15	30
4	10	20
5 OR MORE	5	10

CATEGORY V. SYSTEM IMPLEMENTATION

If the applicant provides documentation of clear budgetary

commitment and documentation of complete plan for system implementation. The application will be awarded the entire 100 points. However, if the documentation does not clearly demonstrate total budget and planning commitment to a complete system then the application will receive a percentage of the total 100 points as determined by the Evaluation Subcommittee.

CATEGORY VI. GEOGRAPHIC EFFICIENCY

The application will be awarded a part of the 100 points based on two factors:

1. the total square-miles of proposed system coverage at a percentage ratio of MOBILES-PER-MILE, and
2. the potential channel reuse, with exceptions to "strip or ribbon" type systems, which will receive a fixed score of 75 points due to the difficulty in calculating efficiency of such systems.

Apply the following formulas:

1. [ (square miles/10) / (square miles/mobiles) = % FACTOR ]
2. [ POINTS AWARD = % FACTOR \* 50 ]

Example: A County Government entity requests a 5 channel system for a proposed system in a geographic area having 325 square miles and a

APPENDIX C

REGION 28 PLAN  
 (As defined in)  
 FCC Gen. Docket No. 87-112

POPULATION IN THE REGIONAL PLANNING AREA  
 1988 & 2000

County (by State)	Population 1988	Population 2000	Change	Percent Change
<u>Delaware</u>				
Kent	108,050	129,900	21,850	20.2
New Castle	428,950	484,650	55,700	13.0
Sussex	114,400	140,200	25,800	22.6
<u>Total Delaware</u>	<u>651,400</u>	<u>753,750</u>	<u>102,350</u>	<u>15.7</u>
<u>New Jersey</u>				
Atlantic	208,542	260,100	51,558	24.7
Burlington	388,129	467,200	79,071	20.3
Camden	496,318	577,200	107,882	16.3
Cape May	94,160	113,000	18,840	20.0
Cumberland	137,571	151,500	13,929	10.1
Gloucester	213,043	249,100	36,057	16.9
Ocean	402,998	484,400	81,402	20.2
Salem	65,371	71,000	5,629	8.6
<u>Total New Jersey</u>	<u>2,006,132</u>	<u>2,373,500</u>	<u>394,368</u>	<u>18.0</u>
<u>Pennsylvania</u>				
Berks	317,194	342,506	25,312	7.9
Bradford	63,970	69,612	5,642	8.8
Bucks	508,576	538,480	29,904	5.8
Carbon	54,011	57,980	3,969	7.3
Chester	334,598	432,958	98,369	29.4
Columbia	61,832	63,130	1,298	2.0
Dauphin	235,811	286,464	50,653	21.5
Delaware	551,359	562,937	11,578	2.1
Lackawanna	223,977	228,680	4,683	2.1
Lancaster	381,348	485,456	104,108	27.3
Lebanon	111,272	125,993	14,721	10.3
Lehigh	276,507	298,572	22,065	8.0
Luzerne	336,380	343,443	7,063	2.1
Lycoming	117,131	119,131	2,459	2.1
Monroe	77,222	122,628	45,406	58.8
Montgomery	658,999	742,032	83,033	12.6
Montour	16,993	18,670	1,677	9.9

APPENDIX C

REGION 28 PLAN  
 (As defined in)  
 FCC Gen. Docket No. 87-112

POPULATION DENSITY OF COUNTIES IN THE REGIONAL PLANNING AREA  
 1988 & 2000

County (by State)	Population 1988	Population 2000	Change	Percent Change
Northampton	230,813	259,895	29,082	12.6
Northumberland	100,211	102,315	2,104	2.1
Philadelphia	1,646,713	1,681,294	34,581	2.1
Pike	20,584	34,286	13,702	66.6
Schuylkill	157,681	160,992	3,311	2.1
Sullivan	6,202	6,332	130	2.1
Susquehanna	38,979	44,912	5,933	15.3
Tioga	40,286	41,132	846	2.1
Wayne	37,797	52,084	14,287	37.8
Wyoming	27,344	32,225	4,881	17.9
York	322,391	373,167	50,776	15.7
<u>Total Pennsylvania</u>	<u>6,956,172</u>	<u>7,627,265</u>	<u>671,593</u>	<u>9.7</u>
<u>Total Area</u>	<u>9,613,704</u>	<u>10,754,515</u>	<u>1,168,311</u>	<u>12.0</u>

Source: Delaware Development Office, Business Statistics Section (State of Delaware), New Jersey Office of Demographic and Economic Analysis (New Jersey), U.S. Department of Commerce, Bureau of Census (Pennsylvania).

Region 28 Plan, per  
 FCC Gen.Doc. 87-112

APPENDIX D

REGION 28 PLAN  
 (As defined in)  
 FCC Gen. Docket No. 87-112

POPULATION DENSITY OF COUNTIES IN THE REGIONAL PLANNING AREA  
 1988 & 2000

County (by State)	Square Miles	People per Square Mile	
		1988	2000
<u>Delaware</u>			
Kent	595	182	218
New Castle	437	982	1,109
Sussex	946	121	148
<u>Total Delaware</u>	1,978	329	381
<u>New Jersey</u>			
Atlantic	567	368	459
Burlington	818	475	571
Camden	222	2,236	2,600
Cape May	263	358	430
Cumberland	504	273	301
Gloucester	328	649	760
Ocean	637	633	760
Salem	351	186	202
<u>Total New Jersey</u>	3,690	544	643
<u>Pennsylvania</u>			
Berks	862	368	397
Bradford	1,148	56	61
Bucks	614	828	877
Carbon	404	134	744
Chester	761	440	569
Columbia	484	128	130
Dauphin	518	455	553
Delaware	184	2,997	3,059
Lackawanna	454	493	504
Lancaster	946	403	513
Lebanon	363	307	347
Lehigh	348	795	858
Luzerne	886	380	388
Lycoming	1,215	96	98
Monroe	611	126	201
Montgomery	496	1,329	1,496
Montour	130	131	144

Region 28 Plan, per  
 FCC Gen.Doc. 87-112

APPENDIX D

REGION 28 PLAN  
 (As defined in)  
 FCC Gen. Docket No. 87-112

POPULATION DENSITY OF COUNTIES IN THE REGIONAL PLANNING AREA  
 1988 & 2000

County (by State)	Square Miles	People per Square Mile	
		1988	2000
Northampton	376	614	691
Northumberland	453	221	226
Philadelphia	129	12,765	13,080
Pike	542	38	63
Schuykill	784	201	205
Sullivan	478	13	13
Susquehanna	833	47	54
Tioga	1,146	35	36
Wayne	741	51	70
Wyoming	398	69	81
York	909	346	411
<u>Total Pennsylvania</u>	17,213	404	443
<u>Total Area</u>	22,881	420	470

Source: Delaware Development Office, Business Statistics Section (State of Delaware), New Jersey Office of Demographic and Economic Analysis (New Jersey), U.S. Department of Commerce, Bureau of Census (Pennsylvania).



89 JUL 27 AM 10: 52

July 21, 1989

Mr. Martin G. Ficke, Director  
Secretary for Region 28  
County of Bucks  
Department of Communications  
Administration Building  
Broad & Court Streets  
Doylestown, Pennsylvania 18901

Dear Mr. Ficke:

Please consider this letter our written authorization for you to reproduce one hundred (100) copies of our map No: 207-Delaware, 228-New Jersey, 236-Pennsylvania, and our County/Town-Middle Atlantic United States Map. Our normal copyright fee has been waived in this instance; however, our mandatory copyright line must remain on all reproductions.

If additional copies are required another waiver must be obtained.

Trusting we have been of assistance to you, we are

Very truly yours,

(Mrs.) Kathleen Roche  
Copyright Division

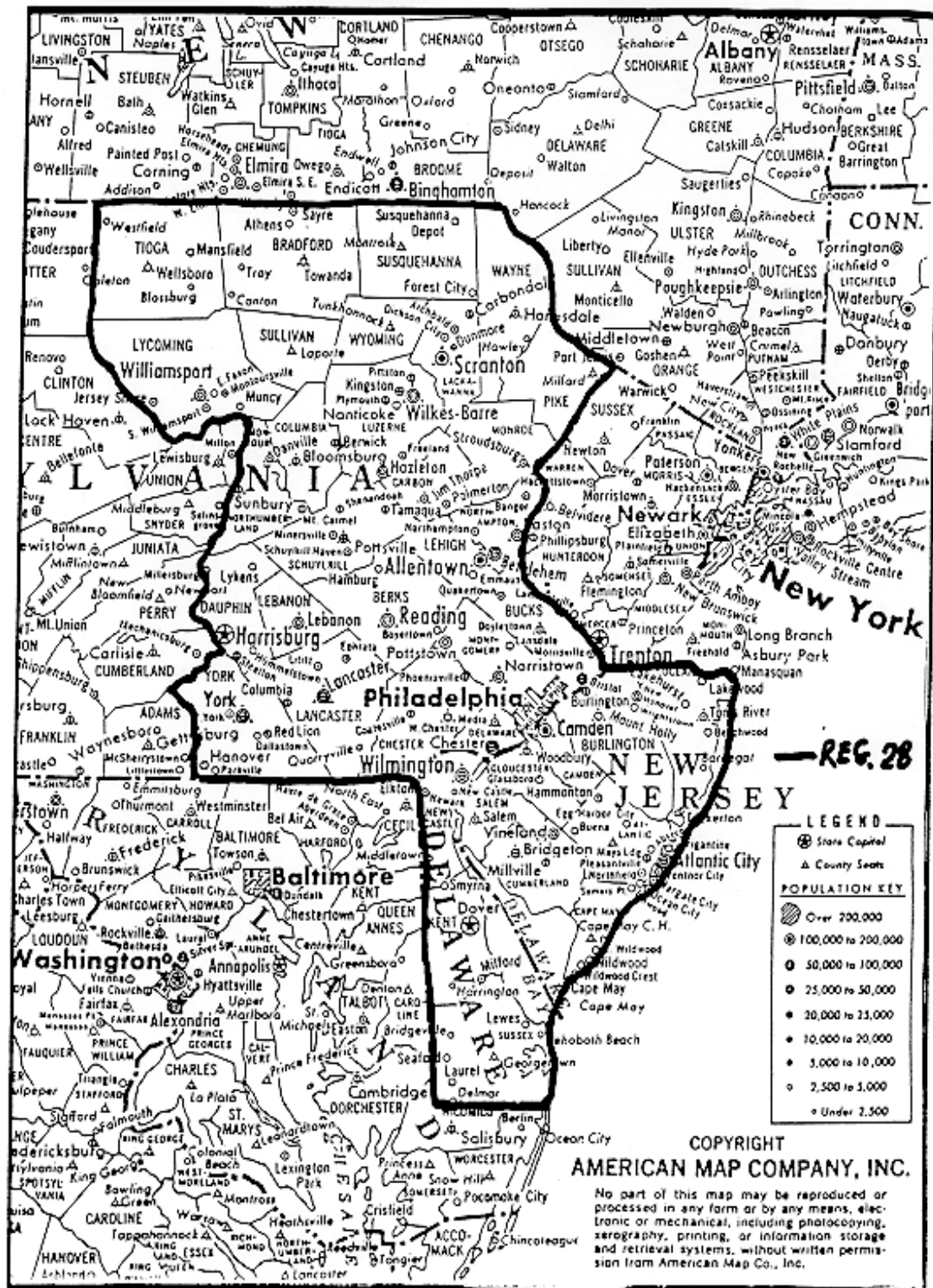

## **FREQUENCY ASSIGNMENT METHODOLOGY**

### **INTRODUCTION:**

The frequency assignment methodology used is a two stage process. The first stage is to assign channels, to the degree possible, to all eligibles who have applied for them in accordance with the plan. The second stage is to create frequency pools to be used by future applicants for channels which satisfy the coverage and interference parameters to be defined later in this section.

### **DESIRED COVERAGE:**

The desired coverage of a system is considered to be, as a maximum, three (3) miles outside of the applicant's jurisdiction. The maximum desired mean signal strength at this contour shall not exceed +40dbu (+40db above one microvolt per meter). In order to allow for practical system design, the 3 mile pad may be altered on a case-by-case basis, and the minimum coverage radius in all cases shall be five (5) miles.

### **CO-CHANNEL INTERFERENCE:**

Co-channel assignments will be made when it is determined that the two or more systems will create a signal strength of +5dbu or less anywhere within their co-channel partner's boundary.

### **ADJACENT CHANNEL INTERFERENCE:**

Adjacent channel assignments will be made when it is determined that the two or more systems will create a signal strength of +25dbu or less anywhere within their adjacent channel partner's boundary.

### **MISCELLANEOUS CONSIDERATIONS:**

for practical engineering reasons in the area of transmitter combining, frequency assignments for the same site, for the same applicant, will be spaced 0.25 MHZ apart, to the degree possible.

### **COMPUTER MODEL:**

The computer propagation model used to calculate the desired mean signal strength is Okumura/Hata. This model has been shown to provide the most accurate results in this frequency band.

### **COMPUTER AIDED ASSIGNMENTS:**

A computer program is used to do the many calculations and iterations required to solve an otherwise impossible task of efficient channel usage.

Inputs to the program include the applicant's identification, location, coverage requirements and number of channels. The computer will take all of the inputs and find, if possible, a solution of specific channel assignments which meet the coverage and interference parameters stated above using the minimum number of channels.

Following this stage, future assignments are considered by creating compatible pools of channels based on growth projections of population.

Before the  
Federal Communications Commission  
Washington, D.C. 20554

Gen. Docket No. 89-573

In the Matter of  
  
Philadelphia Metropolitan Area  
Public Safety Plan

ORDER

Adopted: December 16, 1993; Released: December 27, 1993

By the Chief, Land Mobile and Microwave Division and  
the Acting Chief, Spectrum Engineering Division:

1. The Private Radio Bureau and the Office of Engineering and Technology, acting under delegated authority, accepted the Philadelphia Metropolitan Area (Region 28) Public Safety Plan (Plan) on February 2, 1990, 3 FCC Rcd 3067 (1990).

2. By letter dated June 28, 1993, the Region proposed to amend its Plan. The proposed amendment would revise the current channel allotments. The Commission placed the letter on Public Notice for comments due on August 27, 1993, 38 FR 40818 (July 30, 1993). The Commission received comments from the Tri-State Radio Planning Committee (Region 8) and several groups associated with it. As a result of these comments, Region 28 and Region 8 held a meeting to resolve the differences between the two regions. A new amendment was filed by Region 28 on November 3, 1993, to reflect the agreements reached as a result of the meeting between the two regions.

3. We have reviewed the proposed amendment to the Region 28 Plan and conclude it furthers the interests of the eligible entities within the Region.

4. Accordingly, IT IS ORDERED that the Public Safety Radio Plan for the Philadelphia Metropolitan Area (Region 28) IS AMENDED, as set forth in the Region's letter of June 28 and its subsequent letter of November 3, 1993. This Amendment is effective immediately.

FEDERAL COMMUNICATIONS COMMISSION

Richard J. Shiben  
Chief, Land Mobile & Microwave Division

Lawrence P. Petak  
Acting Chief, Spectrum Engineering  
Division

**REGION 28 Channel Assignment**

**APPENDIX F-3**

**As Approved by FCC Gen. Docket #89-573 on December 12, 1993 (Filing window #3)**

**Listed by Agency:**

State of Pennsylvania, Lackawanna County	604	662	680	682	756	776	795
	798	816	818				
State of Pennsylvania, York County	604	642	680	718	774	795	
Chester County, PA (County wide)	604	609	616	630	646	657	666
	701	760	772				
State of Delaware, Kent County	605	649	651	685	725	727	749
<b>Note: Channels striked out were not licensed, but remain as pool channels for assignment. (Window #4)</b>	803	811	823		<del>635</del>	<del>653</del>	<del>661</del>
	<del>663</del>	<del>673</del>	<del>751</del>	<del>789</del>	<del>791</del>	<del>795</del>	<del>805</del>
State of Pennsylvania, Susquehanna County	606	642	701	718	739		
State of Pennsylvania, Lycoming County	606	626	644	682	718		
State of Pennsylvania, Berks County	606	627	683	797	817		
State of Delaware, Sussex County	607	628	682	703	721	740	758
<b>Channels striked out were not licensed. They remain pool channels for assignment. (Window #4)</b>	760	779	798	<del>646</del>	<del>666</del>	<del>701</del>	<del>742</del>
City of Philadelphia, PA	607	622	626	628	644	660	662
	664	680	682	684	698	703	718
	720	736	738	740	742	756	758
	774	776	778	794	796	798	814
	816	818					
State of Pennsylvania, Luzerne County	608	630	648	668	686	706	722
	724	744	800	820			

**REGION 28 Channel Assignment****APPENDIX F-4**

As Approved by FCC Gen. Docket #89-573 on December 12, 1993 (Filing window #3)

**Listed by Agency:**

City of Reading, PA	623	625	643	699	757	777	
State of Pennsylvania, Wyoming County	624	627	646	742			
NJ State Police, Statewide	624	700					
State of Pennsylvania, Dauphin County	629	645	647	685	703	705	721
	723	741	743	759	761	781	799
PA State Police, Statewide	634	723					
State of Pennsylvania, Lancaster County	637	657	661	693	713	733	771
	815	819	830				
State of Pennsylvania, Carbon County	645	665	703	718	720	736	741
	759	774					
NJ State Police	646	692	726	762	786	792	
State of Pennsylvania, Montour County	650	763	783	803	823		
State of Pennsylvania, Northampton County	659	783	785	809			
State of Pennsylvania, Columbia County	660	701	739	779	815		
City of Bethlehem, PA	661	663	681	739	795	815	
State of Pennsylvania, Pike County	610	626	628	684	814		

**REGION 28 Channel Assignment****APPENDIX F-5**

**Listed by Agency:**

State of Pennsylvania, Lebanon County	610	794	801	821			
State of Pennsylvania, Bradford County	611	684	761	781			
State of Pennsylvania, <b>*Southeast PA Area</b>	611	614	650	652	670	672	688
<b>* Include: Chester County, Delaware County,</b>	690	728	746	748	764	766	780
<b>Pennsylvania County, and Montgomery County</b>	800	804	806	822	824		
State of Pennsylvania, Northumberland County	613	633	671	689	698		
City of Trenton, NJ	617	655	658	707	709	730	768
<b>*Low Power Tactical use only</b>	<b>826*</b>	<b>828*</b>					
State of Pennsylvania, Lehigh County	618	654	657	695	708	710	731
	827	830					
State of Delaware, New Castle County	618	638	642	655	678	<b>692*</b>	694
<b>*Low Power Tactical use only</b>	714	730	732	<b>762*</b>	768	782	808
	826	828					
Montgomery County, PA	620	648	668	686	696	705	812
State of Pennsylvania, Monroe County	622	698	761	778	780		
State of Pennsylvania, Dauphin County	622	698	736	794	814		
State of Pennsylvania, Sullivan County	663	757	777	797			



**Pending Approval by the FCC (Filing window #4)**

*The following Assignments are pending submittal to the FCC for approval. They are listed here only for planning purposes until FCC approval is granted.*

**Listed by Agency:**

Cherry Hill Township, NJ	632	733	783	809	667		
<del>Burlington County, NJ</del> Region 8 would not CONCUR with any of these Ch.	830	640	678	716	754		
Ocean County, NJ * <del>CW-Data</del> Region 8 would not CONCUR to use of Ch. 603	603*	629					
Cumberland County NJ	602	621	631	697	708	717	755
Atlantic County, NJ	610	615	643	654	669	687	704
	722	729	741	757	765	775	781
	797	807	813	817	821	825	
Montgomery County, PA - <b>Mobile Only Use</b> Region 8 Imposed limits: <sup>1</sup> No Aeronautical Operation on Ch. 602 <sup>2</sup> Letter of Concurrence from NJ State Police on Ch.725 & 734"	602 <sup>1</sup>	632	725 <sup>2</sup>	734 <sup>2</sup>	808		

REGION 28 PLAN                      Appendix G  
(As defined in)  
FCC Gen. Docket No. 87-112

COMMITTEE MEMBERS

LEGEND:

Last Name, First Name                      Organization  
Address  
Office Phone Number    FAX Number    Active/observer    Environment  
\*\*\*\*\*

Amster, Mike                                      Motorola C & E, Inc.  
301 Masons Mill Road, Huntingdon Valley PA 19006  
215 657 7880    215 657 0985                      Active Participant    Vendor

Assaiante, Alfred A.                              New Jersey Govt. Services Admin.  
Treasury Dept., 135 W. Hanover St., CN230 Trenton, NJ 08625  
609 292 9885    609 292 0490                      Active Participant    Public-Safety

Barsuglia, James                                      New Jersey State Police  
Radio Elec. Maint. Unit, P.O. Box 7068, West Trenton, NJ 08625  
609 882 2000    609 882 1463                      Active Participant    Public-Safety

Bauman, Barry M.                                      Lancaster County-wide Communications  
50 North Duke Street, Lancaster, PA 17603  
717 299 8379                      Active Participant    Public-Safety

Baun, Glenn    Southampton Fire Co.  
1324 Stephen Way, Southampton, PA 18966  
215 364 3629                      Active Participant    Public-Safety

Beam, Jack G.    State of Pennsylvania  
Bureau of A. T., 2221 Forster St., Harrisburg, PA 17120  
717 787 7086                      Active Participant    Public-Safety

Black, Franklin    City Of Philadelphia  
Public Prop. Dept., Comm. Div., City Hall, Room 632, Philadelphia, PA 19103  
215 686 4500                      Active Participant    Public-Safety

Bradford, Edward L.                                      Cumberland Co. Communications & Training Ctr.  
RD 8 Bridgeton Avenue, Box 46, Bridgeton, NJ 08302  
609 455 8526                      Observer    Public-Safety

Brown, P.E., Larry M.                                      Pa. Bureau Of Telecom. Services  
State Hospital Grounds, North Circle Drive, Harrisburg, PA 17125  
717 257 3001                      Active Participant    Public-Safety

Brunstetter, Mark    Chester County Department Of Emergency Services  
14 East Biddle Street, West Chester, PA 19380  
215 431 6160                      Active Participant    Public-Safety

MEMBERSHIP

i

9-6-89

Byrne, Thomas                      State Of Pennsylvania  
PENNDOT T & S Building, Room 1005, Harrisburg, PA 17120  
717 787 6248            Observer    Public-Safety

Coltri, Norman                      Frequency Coordination Unit  
New Jersey State Police, P.O. Box 7068, West Trenton, NJ 08625  
609 882 2000    609 882 1463    Active Participant    Public-Safety

Costello, Vincent E, Director      City Of Philadelphia  
Comm. Eng., Dept. Of Public Property, Room 632, City Hall, Phila., PA 19103  
215 686 4500    215 686 9639    Active Participant    Public-Safety

Croft, C. W.                      Bucks County Fire Comm. Advisory Board  
805 Orcher Avenue, Southampton, PA 18966  
215 357 4753            Active Participant    Public-Safety

Cunningham, Lee D., Director      Pennsylvania Turnpike Comm.  
Communications Dept, P.O. Box 8531, Harrisburg, PA 17105  
717 939 9551            Observer    Public-Safety

Dimauro, James F.                      RAM Communications  
1152 St. George Avenue, Avenel, NJ 07001  
201 636 6970            Observer    Vendor

Dutkus, Stanley                      New Jersey State Police  
Radio Elec. Maint. Unit, P.O. Box 7068, West Trenton, NJ 08625  
609 882 2000            Active Participant    Public-Safety

Farro, Wayne J.                      Motorola C & E, Inc.  
301 Masons Mill Road, Huntingdon Valley, PA 19006  
215 657 7880            Observer    Vendor

Ficke, Martin G.                      Bucks Co. Dept. Of Comm.  
Administration Building, Court And Main Streets, Doylestown, PA 18901  
215 348 6626            Active Participant    Public-Safety

Fleissner, Robert W.                      Motorola C & E, Inc.  
85 Harrison Road, Glen Rock, NJ 07452  
201-447-7618            Observer    Vendor

Geden, William                      Essex County Dept. Of Public Works  
900 Bloomfield Avenue, Verona, New Jersey 07044  
201 226 8503            Active Participant    Public-Safety

Gibson, Thomas E.                      Thomas E. Gibson Consultants, Inc.  
2122 Sierra Road, Plymouth Meeting, PA 19462  
215 828 8762            Active Participant    Public-Safety

Gray, Robert                      Pennsylvania Game Commission  
2001 Elmerton Avenue, Harrisburg, PA 17110  
717 787 4023            Observer    Public-Safety

Greenway, Brian R. Pa Emergency Management Agency  
P.O. Box 3321, Harrisburg, PA 17105  
717 783 8150 Active Participant Public-Safety

Groce III, M. Jay Chester County Department Of Emergency Services  
14 East Biddle Street, West Chester, PA 19380  
215 344 6160 Observer Public-Safety

Hale, Weldon P. Department Of General Services  
State Office Bldg., 301 West Preston Street, Baltimore, MD 21201  
301 225 4219 Observer Public-Safety

Hames, Bruce W. Lower Gwynedd Twp. Police Dept.,  
1130 N Bethlehem Pike, Springhouse, PA 19454 Observer Public-Safety

Hibbard, Richard GE Mobile Communications  
992 Old Eagle School Road, Suite 914, Wayne, PA 19087  
215 927 5507 Active Participant Vendor

Hoffman, Gary Monroe County Control Center  
Monroe County Court House, 7th & Sarah Street, Stroudsburg, PA 18360  
717 421 1711 Active Participant Public-Safety

Hoffman, Lantz Pennsylvania Game Commission  
Bureau Of I & B Director, 2001 Elmerton Avenue, Harrisburg, PA 17110  
717 787 6286 Observer Public-Safety

Hollar Jr., John S. Pennsylvania State Police  
1800 Elmerton Avenue, Harrisburg, PA 17110  
717 783 5508 Active Participant Public-Safety

Hugg, David S. Delaware Dept Of Natural Resources  
89 Kings Highway, P.O. Box 1401, Dover, DE 19903  
302 736 3091 Active Participant Public-Safety

Kaplan, Arthur D. Schuylkill Co. EMA  
Courthouse, Pottsville, PA 17901  
717 622 3739 Observer Public-Safety

Keitel, John New Jersey State Police  
Emergency Management, P.O. Box 7068, West Trenton, NJ 08625  
609 882 2000 Active Participant Public-Safety

Kell, Darwin Motorola C & E, Inc.  
1004 Allen Street, New Cumberland, PA 17070  
717 774 5058 717 774 5899 Observer Vendor

Klinger, Robert W. Pennsylvania Attorney General's Office, BCI  
Strawberry Square Bldg., Floor 16, Harrisburg, PA 17120  
717 787 5767 Active Participant Public-Safety

Knecht, Richard A. Lycoming County Emergency Serv  
48 West Third Street, Williamsport, PA 17701  
717 327 2447 717 327 2510 Active Participant Public-Safety

Kowalski, Edward R. City Of Philadelphia  
Comm. Div., Public Prop. Dept., City Hall, Rm 632, Philadelphia, PA 19103  
215 533 1660 Active Participant Public-Safety

Landis, William Motorola C & E, Inc.  
33 N. Whitfield Street, Nazareth, Pa 18064  
215 759 8921 Observer Vendor

Lease, Mike Colmar Vol. Fire Co.  
P.O. Box 92, Colmar, PA 18915  
215 270 2342 Active Participant Public-Safety

Lengel, Richard Montgomery Co. EMS Council  
50 Eagleville Road, Eagleville, PA 19401  
215 326 1508 Observer Public-Safety

Maehling, Peter Convenor, Region 36  
1610 Patomac Avenue, Pittsburgh, PA 15216 Observer Public-Safety

Mariotti, Duane ECRI  
5200 Butler Pike, Plymouth Meeting, PA 19462  
215 825 6000 Active Participant Vendor

Matone, A. Michael Motorola C & E, Inc.  
55 Charles Polk Road, Dover, DE 19901  
302 674 0108 Active Participant Vendor

McClements, Alan E. Delaware Dept. Of Public Safety  
Div. Of Emergency Planning, P.O. Box 527, Delaware City, DE 19706  
302 834 4531 Active Participant Public-Safety

McFadden, John Motorola C & E, Inc.  
301 Masons Mill Road, Huntingdon Valley, PA 19006  
215 657 7880 215 657 0985 Observer Vendor

McGee, Dale GE Mobile Communications Co.  
992 Old Eagle School Rd., Suite 914, Wayne, PA 19087  
215 927 5507 Observer Vendor

McKittrick, Brian K. County Of Lehigh  
455 Hamilton Street, Allentown, PA 18105  
215 434 4843 Active Participant Public-Safety

Miller, Benjamin H. Delaware State Police,  
P.O. Box 430, Dover, DE 19903  
302 736 5854 302 736 1729 Active Participant Public-Safety

Region 28 Plan, per  
FCC Gen.Doc. 87-112

Miller, Chief W. Williamsport Police Dept.  
245 W. 4th Street, Williamsport, PA 17701 Observer Public-Safety

Mineo, Nicholas A. State of Pennsylvania  
Bureau of A. T., 2221 Forster St., Harrisburg, PA 17120  
717 787 7086 Active Participant Public-Safety

Mizialko, Jim Motorola C & E, Inc.  
301 Masons Mill Road, Huntingdon Valley, PA 19006  
215 657 7880 215 657 0985 Observer Vendor

Monahan, Joseph Montgomery County Communications Bureau  
50 Eagleville Road, Eagleville, PA 19403  
215 631 6500 Active Participant Public-Safety

Morrone, Joseph M. City Of Philadelphia  
Room 632 City Hall, Philadelphia, PA 19107  
215 686 4984 Active Participant Public-Safety

Oarney, William Eastern Division, Int. Fire Chief's Assn.  
1413 Wabash Avenue ,northfield, NJ 08225  
609 645 7747 Observer Public-Safety

Pue, Charles H. Phila Fire Dept Fire  
Communications Center, 3rd & Spring Garden Streets, Philadelphia, PA 19123  
215 592 5987 Active Participant Public-Safety

Pusey, Raymond S. Delaware Dept. Of Transportation  
P.O. Box 778, Dover, DE 19903  
302 736 4361 Active Participant Public-Safety

Rabenold, Bruce D. Blue Mountain Control Centre  
29 Mechanic Street, Wind Gap, PA 18091  
213 863 4181 Active Participant Public-Safety

Reynolds, Richard R. Del. Office Of Telecommunications Mgt.  
821 Silver Lake Blvd, Suite 108, Dover, DE 19901  
302 736 9648 302 736 9642 Active Participant Public-Safety

Rotolo, Michael N.J. Turnpike Authority  
P.O. Box 1121, New Brunswick, NJ 08903  
201 247 0900 Observer Public-Safety

Rowntree, John Department Of Public Safety  
100 Grant Street, Pittsburgh, PA 15219  
Active Participant Public-Safety

Region 29 Plan, per  
FCC Gen.Doc. 87-112

Saia, Joseph C. New Jersey State Police  
Communications Bureau, P.O. Box 7068, West Trenton, NJ 08625  
609 882 2000 609 882 1463 Active Participant Public-Safety

Scanlon, Michael Delaware River & Bay Authority  
P.O. Box 71, New Castle, DE 19720  
302 571 6349 Active Participant Public-Safety

Serdynski, Richard GE Mobile Communications  
922 Old Eagle School Road, Suite 914, Wayne, PA 19087  
215-927-5507 215-687-0535 Observer Vendor

Short, T. Fred Special System Services  
1 Wayne Circle, Lower Gwynedd, PA 19002  
215 699 4427 Active Participant Vendor

Skold, Raymond E.F. Johnson Company  
345 Route 17, Upper Saddle River, New Jersey 07458  
201 934 1820 Active Participant Vendor

Sparks, Frank Delaware State Police  
P.O. Box 430, Dover, DE 19903  
302 736 5857 302 736 1729 Active Participant Public-Safety

Truitt, Edwin Delaware County  
Court House, Media, PA 19063  
215 891 5045 Active Participant Public-Safety

Updegrave, Robert W. Radio Communications  
309 Commerce Drive, Exxon, PA 19341  
215 363 5858 Active Participant Vendor

Van Horn Sr., Harry E. Montgomery County Chief's Of Police  
300 Main Street, Royerford, PA 19468  
215 489 0261 Observer Public-Safety

Wallace Sr., George B. Delaware Dept. Of Public Safety  
Division Of Communications, P.O. Box 1946, Dover, DE 19903  
302 697 2590 Active Participant Public-Safety

Westermann, George City Of Philadelphia  
Public Property Department, Room 632, City Hall, Philadelphia, PA 19103  
215 686 4513 Active Participant Public-Safety

Witkowski, Michael Medical Center Of Delaware, Inc.  
P.O. Box 6001, Newark, DE 19718  
302 733 3592 Active Participant Public-Safety

Region 29 Plan, per  
FCC Gen.Doc. 87-112

Wurmb, Steven L.                      Pennsylvania Emergency Health Services Council  
3425 Simpson Ferry Road, Camp Hill, PA 17011  
717 763 4678                      Active Participant                      Public-Safety

Yates, David                              Cumberland County Communications Center  
Rd 8, Bridgeton Avenue, Box 46, Bridgeton, NJ 08302  
609 455 8526                      Observer                      Public-Safety

Zacher, Harry                              City Of Philadelphia, Communications Div  
Public Prop Dept, City Hall, Rm 632, Philadelphia, PA 19103  
215 686 4500                      215 686 9639 Active Participant                      Public-Safety

Region 29 Plan, per  
FCC Gen.Doc. 87-112

TASKS GROUPS

Scope and Authority

Ficke, Martin G., Task Chairman (PA)  
Baun, Glen (PA)  
Croft, C. W. (PA)  
Keitel, John (NJ)

Spectrum Utilization

Saia, Joseph, Task Chairman (NJ)  
Amster, Michael (PA)  
Assaiante, Alfred A. (NJ)  
Bradford III, Edward L. (NJ)  
Coltri, Norman (NJ)  
Dutkus, Stanley (NJ)  
Keitel, John (NJ)  
Lease, Mike (PA)  
Mariotti, Duane (PA)  
Matone, Michael A. (DE)  
Wallace Sr., George B. (DE)

Communication Requirements

Zacher, Harry, Task Chairman (Former)(PA)  
Kowalski, Edward R., Task Chairman (Former) (PA)  
Pue, Charles, Task Chairman (Present) (PA)  
Amster, Michael (PA)  
Hibbard, Richard (PA)  
Kowalski, Edward (PA)  
McGee, Dale (PA)  
Mizialco, Jim (PA)  
Short, Fred (PA)

Implementation and Procedures

Reynolds, Richard, Task Chairman (DE)  
Amster, Michael (PA)  
Assaiante, Alfred A. (NJ)  
Coltri, Norman R. (NJ)  
Hugg III, David S. (DEL)  
Mariotti, Duane A. (PA)  
Matone, Michael A. (DEL)  
Pusey, Raymond S. (DEL)  
Rabenold, Bruce D. (PA)  
Scanlon, Michael R. (DEL)  
Updegrave, Robert W. (PA)  
Witkowski, Michael (DEL)

Region 29 Plan, per  
FCC Gen.Doc. 87-112

Epilogue

Hollar Jr., John S., Task Chairman (PA)  
Bauman, Barry M. (PA)  
Greenway, Brian R. (PA)  
Landis, William E. (PA)  
Kaplin, Arthur D. (PA)  
McKittrick, Brian K. (PA)

Channelization Subcommittee

Reynolds, Richard, Task Chairman (DE)  
Assaiante, Alfred A. (NJ)  
Beam, Jack G. (PA)  
Coltri, Norman (NJ)  
Miller, Benjamin H. (DE)  
Monahan, Joseph (PA)

Evaluation Subcommittee

Gibson, Thomas E., Subcommittee Chairman  
Coltri, Norman, Frequency Coordinator, New Jersey  
Ficke, Martin G. (Task Group Chairman for "Scope" and "Authority")  
Hollar, Jr., John S. (Task Group Chairman "Epilogue")  
Monahan, Joseph, APCO Frequency Coordinator  
Pue, Charles (Task Group Chairman "Communication Requirements")  
Reynolds, Richard, Frequency Coordinator, Delaware  
Saia, Joseph (Task Group Chairman "Spectrum Utilization")

REGION 28 PLAN      APPENDIX H  
(As defined in)  
FCC Gen. Docket No. 87-112

CONVENING MEETING NOTIFICATION LIST

PUBLIC SAFETY ADMINISTRATORS

Herb Antell Mobile Communications Unit Police Admin. Bldg. 106 Philadelphia, PA 19106 215-592-5853	Barry Bauman Lancaster County Comm 50 North Duke Street Lancaster, PA 17602 717-299-4321
Paul Beatty Box 175 Marion Center, PA 412-349-1428	Mark Brunstetter Chester County Department of Emergency Services West Chester, PA 19380 215-431-6160
Captain Robert Butler Philadelphia Police Dept. Franklin Plaza 8TH and Race Streets Philadelphia, PA 19106	Sue Cavanaugh Westmoreland County Comm. RD #1 BOX 305 Scottsdale, PA 15683
Norman Coltri New Jersey State Police P.O. BOX 7068 West Trenton, NJ 08628	Stanley Dutkus New Jersey State Police P.O. BOX 7068 West Trenton, NJ 08628
Marty Ficke Bucks County Communications Court House Doylestown, PA 18901	James Flaherty Gloucester County Comm. 1200 Delsea Drive Clayton, NJ 08312
Richard Flynn PA Emergency Health Services Council 3425 Simpson Ferry Road Camp Hill, PA 17011	James Giannini Director Of Communications 50 Eagleville Road Eagleville, PA 19403 215-631-6500

Region 28 Plan, per  
FCC Gen.Doc. 87-112

APPENDIX H

Thomas Gibson  
2122 Sierra Road  
Plymouth Meeting, PA 19462  
215-828-8762

Timothy Gill  
Chief Of Operations  
Court House  
Media, PA 19063  
215-565-8700

Brian Greenway  
Pennsylvania Emergency  
Management Agency  
P.O. BOX 3321  
Harrisburg, PA 17105

M. Jay Groce III  
Department Of  
Emergency Services  
14 East Biddle Street  
West Chester, PA 19380  
215-431-6160

John S. Hollar, Jr.  
Pennsylvania State  
Police Headquarters  
1800 Elmerton Ave.  
Harrisburg, PA 17110  
717-783-5508

George Hughes  
Chester County Department  
Of Emergency Services  
14 East Biddle Street  
West Chester, PA 19380  
215-431-6160

Horman Jadczyk  
Philadelphia Water Dept.  
Northeast Treatment Plant  
3900 Richmond Street  
Philadelphia, PA 19137

Irv Lichtenstein  
704 Preston Rd.  
Erdenheim, PA 19118

Peter Maehling  
Engineered Communications,  
Incorporated  
1610 Potomac Ave.  
Pittsburgh, PA 15216  
412-344-9000

Mark Martarano  
Pittsburgh Department Of  
Public Safety  
100 Grant St., 3rd Floor  
Pittsburgh, PA 15219

Matthew Mathiesin  
Pa Department Of Health  
Health And Welfare Bldg.  
Room 1003  
Harrisburg, PA 17120

Bud Mccollum  
P.O. Box 145  
Penns Park, PA 18943

John McEwen  
Clarion County Comm.  
220 Penn State  
New Bethlehem, PA 16242  
814-226-6631

James McKernan  
Fire Administration Building  
3rd and Spring Garden Sts.  
Philadelphia, PA 19123

Region 28 Plan, per  
FCC Gen.Doc. 87-112

APPENDIX H

S. Robert Miller  
Gloucester County Comm.  
1200 North Delsea Dr.  
Clayton, NJ 08312  
609-881-2211

Nick Mineo  
Bureau Of Telecommunications  
And Information Technology  
2221 Forster St.  
Harrisburg, PA 17125

Joseph Monahan  
Communications Engineer  
50 Eagleville Rd.  
Eagleville, PA 19403  
215-631-6500

Joseph M. Morrone  
Room 632 City Hall  
Philadelphia, PA 19107  
215-686-4984

William Mosler  
C/O E. F. Johnson  
Box 475  
Glenside, PA 19038

Charles Pue  
Fire Administration Building  
3rd And Spring Garden Sts.  
Philadelphia, PA 19123

Richard Reynolds  
Office Of Telecommunications  
821 Silver Lake Blvd.  
Suite 108  
Dover, DE 19901  
302-736-9648

John Rowntree  
Pittsburgh Department Of  
Public Safety  
100 Grant Street, 3rd Floor  
Pittsburgh, PA 15219

Jack Rupert  
Director Of Communications  
Lycoming County  
48 West Third St.  
Williamsport, PA 17701  
717-327-2447

Joseph C. Saia  
New Jersey State Police  
Communications Bureau  
P.O. Box 7068  
West Trenton, NJ 08625  
609-882-2000

Tom Shuler  
PSR Consultants Inc  
329 Laurel Dr.  
Trappe, Pa 19426  
215-489-0686

Edward Truitt  
Director Of Communications  
Delaware County Communications  
Court House  
Media, PA 19063  
215-565-8700

Robert Updegrave  
932 Eddystone Ave.  
Eddystone, PA 19103  
215-874-7100

Emil T. Vogel  
Spectrum Resource Manager  
Motorola Gov. Marketing Div.  
85 Harristown Rd.  
Glen Rock, NJ 07452  
201-447-4000

Region 28 Plan, per  
FCC Gen.Doc. 87-112

APPENDIX H

David E. Wolfe  
Communications Div.  
Pennsylvania State Police  
1800 Elmerton Ave.  
Harrisburg, PA 17110  
717-783-5508

Theodore Wise  
Director Of Communications  
Cumberland County Court House  
Carlisle, PA 17110  
717-249-9922

Harry Zacher  
City Hall Room 632  
Philadelphia, PA 19107  
215-686-4500

PUBLICATIONS

Communications Magazine  
6530 South Yosemite Street  
Englewood, CO 80111

Mobile Radio Technology  
P.O. Box 12901  
Overland Park, KS 66212

RCR Publications  
1728 Downing Street  
Denver, CO 80218

STATE CONTACT PERSONS (SUPPLIED BY APCO)

Francine Booth  
State Single Point of Contact  
Executive Department  
Thomas Collins Building  
Dover, DE 19903

Nelson Silver  
State Review Process  
Department of Community Affairs, CN 803  
Trenton, NJ 08625-0803

Laine A. Heltebride  
Special Assistant  
Pennsylvania Intergovernmental Council  
P.O. Box 11880  
Harrisburg, PA 17108

REGION 28 PLAN      APPENDIX I  
(As defined in)  
FCC Gen. Docket No. 87-112

COMMITTEE RULES

1. After being recognized by the Chair any person may address the meeting.
2. Quorum is at least 2 members, each representing a different agency from each state (Del., PA., N.J.) plus the Chair or the Chair's Alternate.
3. One vote per eligible agency. Any number of members in an agency may participate, but the agency has only one vote.
4. All motions require a simple majority of eligible agencies present in order to carry the motion.
5. Regular meeting dates to be scheduled in advance about once a month.
6. Special meetings to be called by the Chair with seven day's notice.
7. Eligible members may submit agenda items to the Chair up to two weeks prior to the next scheduled meeting.

REGION 28 PLAN                      Appendix J  
(As defined in)  
FCC Gen. Docket No. 87-112

PARTICIPATING AGENCIES

Baltimore (MD) Department of General Services  
State Office Bldg., 301 West Preston Street, Baltimore, Maryland 21201

Blue Mountain (PA) Control Centre  
29 Mechanic Street, Wind Gap, Pennsylvania 18091

Bucks County (PA) Department of Communications  
Administration Building, Court & Main Streets, Doylestown, PA. 18901

Bucks County (PA) Fire Communications Advisory Board  
805 Orcher Avenue, Southampton, Pennsylvania 18966

Chester County (PA) Department of Emergency Services  
14 East Biddle Street, West Chester, Pennsylvania 19380

Colmar (PA) Vol. Fire Company  
P.O. Box 92, Colmar, Pennsylvania 18915

Convenor, Region 36  
1610 Patonac Avenue, Pittsburgh, Pennsylvania 15216

Cumberland County (NJ) Communications & Training Center  
RD 8 Bridgeton Avenue, Box 46, Bridgeton, New Jersey 08302

Delaware County (PA) Department of Communications  
Court House, Media, Pennsylvania 19063

Delaware Department of Public Safety  
Div. of Emergency Planning, P.O. Box 527, Delaware City, Delaware 19706

Delaware Department of Public Safety  
Division of Communications, P.O. Box 1946, Dover, Delaware 19903

Delaware Department of Natural Resources  
89 Kings Highway, PO Box 1401, Dover, Delaware 19903

Delaware Department of Transportation  
P.O. Box 778, Dover, Delaware 19903

Delaware Office of Telecommunications Management  
821 Silver Lake Blvd, Suite 108, Dover, Delaware 19901

Participating Agencies                      i

Region 28 Plan, per  
FCC Gen.Doc. 87-112

Appendix J

Delaware River & Bay Authority  
P.O. Box 71, New Castle, Delaware 19720

Delaware State Police  
P.O. Box 430, Dover, Delaware 19903

E.F. Johnson Company  
345 Route 17, Upper Saddle River, New Jersey 07458

ECRI  
5200 Butler Pike, Plymouth Meeting, Pennsylvania 19462

Essex County (NJ) Department of Public Works  
900 Bloomfield Avenue, Verona, New Jersey 07044

General Electric  
992 Old Eagle School Road, Suite 914, Wayne, Pennsylvania 19087

International Fire Chief's Association, Eastern Division  
1413 Wabash Avenue, Northfield, New Jersey 08225

Lancaster County (PA) County-wide Communications  
50 North Duke Street, Lancaster, Pennsylvania 17603

Lehigh County, Pennsylvania  
455 Hamilton Street, Allentown, Pennsylvania 18105

Lower Gwynedd Twp. (PA) Police Department  
1130 N. Bethlehem Pike, Springhouse, Pennsylvania 19454

Lycoming County (PA) Emergency Services  
48 West Third Street, Williamsport, Pennsylvania 17701

Medical Center of Delaware, Inc.  
P.O. Box 6001, Newark, Delaware 19718

Monroe County (PA) Control Center  
Monroe County Court House, 7th & Sarah Street, Stroudsburg, PA 18360

Montgomery County (PA) EMS Council  
50 Eagleville Road, Eagleville, Pennsylvania 19401

Montgomery County (PA) Communications Bureau  
50 Eagleville Road, Eagleville, Pennsylvania 19403

Montgomery County (PA) Chief's of Police  
300 Main Street, Royerford, Pennsylvania 19468

Region 28 Plan, per  
FCC Gen.Doc. 87-112

Appendix J

Motorola C & E Inc.,  
55 Charles Polk Road, Dover, Delaware 19901

Motorola C & E Inc.,  
301 Masons Mill Road, Huntingdon Valley, Pennsylvania 19006

Motorola C & E Inc.,  
1004 Allen Street, New Cumberland, Pennsylvania 17070

Motorola C & E Inc.,  
33 N. Whitfield Street, Nazareth, Pennsylvania 18064

New Jersey Frequency Coordination Unit  
New Jersey State Police, P.O. Box 7068, West Trenton, New Jersey 08625

New Jersey Government Services Administration  
Treasury Dept., 135 W. Hanover St., Cn230 Trenton, New Jersey 08625

New Jersey State Police  
Communications Bureau, P.O. Box 7068, West Trenton, New Jersey 08625

New Jersey State Police  
Emergency Management, P.O. Box 7068, West Trenton, New Jersey 08625

New Jersey Turnpike Authority  
P.O. Box 1121, New Brunswick, New Jersey 08903

Pennsylvania Attorney General's Office, BCI  
Strawberry Square Bldg., Floor 16, Harrisburg, Pennsylvania 17120

Pennsylvania Bureau of Telecommunication & Info. Tech Ser.  
P.O. Box 1365, Harrisburg, Pennsylvania 17125

Pennsylvania Bureau of Telecommunication Services  
State Hospital Grounds, North Circle Drive, Harrisburg, Pennsylvania 17125

Pennsylvania Emergency Health Services Council  
3425 Simpson Ferry Road, Camp Hill, Pennsylvania 17011

Pennsylvania Emergency Management Agency  
P.O. Box 3321, Harrisburg, Pennsylvania 17105

Pennsylvania Game Commission  
2001 Elmerton Avenue, Harrisburg, Pennsylvania 17110

Pennsylvania (State of)  
Dept. of Gen. Ser., North Circle Dr., State Hospital Grounds, Box 1365,  
Harrisburg, Pennsylvania 17110

Participating Agencies

iii

Region 28 Plan, per  
FCC Gen.Doc. 87-112

Appendix J

Pennsylvania (State of)  
PennDOT T & S Building, Room 1005, Harrisburg, Pennsylvania 17120

Pennsylvania State Police  
1800 Elmerton Avenue, Harrisburg, Pennsylvania 17110

Pennsylvania Turnpike Commission  
Communications Dept, P.O. Box 8531, Harrisburg, Pennsylvania 17105

Philadelphia (City of)  
Comm. Div., Public Prop. Dept., City Hall, Rm 632, Philadelphia, PA 19103

Philadelphia Fire Department  
Fire Comm. Center, 3rd & Spring Garden Streets, Philadelphia, Pa 19123

Pittsburgh Department of Public Safety  
100 Grant Street, Pittsburgh, Pennsylvania 15219

Radio Communications  
309 Commerce Drive, Exton, Pennsylvania 19341

RAM Communications  
1152 St. George Avenue, Avenel, New Jersey 07001

Schuylkill County (PA) Emergency Management Agency  
Courthouse, Pottsville, Pennsylvania 17901

Special System Services  
1 Wayne Circle, Lower Gwynedd, Pennsylvania 19002

Thomas E. Gibson Consultants, Inc.  
2122 Sierra Road, Plymouth Meeting, Pennsylvania 19462

Williamsport (PA) Police Dept.  
245 W. 4th Street, Williamsport, Pennsylvania 17701

Participating Agencies

iv

REGION 28 PLAN  
(As defined in)  
FCC Gen. Docket No. 87-112

APPENDIX K-1

REGION 28 PLANNING COMMITTEE  
2122 SIERRA ROAD  
PLYMOUTH MEETING, PA 19462  
215-828-8762

SEPTEMBER 8, 1989

Carroll White, Administrator  
Region 8  
Port Authority of NY/NJ  
Suite 625  
One World Trade Center  
New York, NY 10048

Dear Carroll:

I am enclosing a copy of the Region 28 draft plan which we hope to submit to the FCC shortly. I would appreciate any comments that you may have.

Please respond by September 22nd as we would like to submit by October 1st.

Thank you for your consideration and my best regards to the membership of your committee.

Sincerely yours,

  
Thomas E. Gibson  
Chairman

Enclosure

REGION 28 PLAN  
(As defined in)  
FCC Gen. Docket No. 87-112

APPENDIX K-2

REGION 28 PLANNING COMMITTEE  
2122 SIERRA ROAD  
PLYMOUTH MEETING, PA 19462  
215-828-8762

SEPTEMBER 8, 1989

Weldon Hale, Chairman  
Region 28  
Telecomm Division of General Services  
Room 1304  
301 W. Preston  
Baltimore, MD 21202

Dear Weldon:

I am enclosing a copy of the Region 28 draft plan which we hope to submit to the FCC shortly. I would appreciate any comments that you may have.

Please respond by September 22nd as we would like to submit by October 1st.

Thank you for your consideration and my best regards to the membership of your committee.

Sincerely yours,

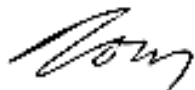

Thomas E. Gibson  
Chairman

Enclosure

REGION 28 PLAN  
(As defined in)  
FCC Gen. Docket No. 87-112

APPENDIX K-3

REGION 28 PLANNING COMMITTEE  
2122 SIERRA ROAD  
PLYMOUTH MEETING, PA 19462  
215-828-8762

SEPTEMBER 8, 1989

Paul Schoenwolf, Chairman  
Region 30  
N Y Association of Fire Chiefs  
2134 Orchard Park  
Schenectady, NY 12309

Dear Paul:

I am enclosing a copy of the Region 28 draft plan which we hope to submit to the FCC shortly. I would appreciate any comments that you may have.

Please respond by September 22nd as we would like to submit by October 1st.

Thank you for your consideration and my best regards to the membership of your committee.

Sincerely yours,

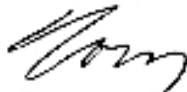

Thomas E. Gibson  
Chairman

Enclosure

REGION 28 PLAN  
(As defined in)  
FCC Gen. Docket No. 87-112

APPENDIX K-4

REGION 28 PLANNING COMMITTEE  
2122 SIERRA ROAD  
PLYMOUTH MEETING, PA 19462  
215-828-8762

SEPTEMBER 8, 1989

John S. Hollan, Jr., Chairman  
Region 36  
Pennsylvania State Police  
1800 Elmenton Avenue  
Harrisburg, PA 17110

Dear John:

I am enclosing a copy of the Region 28 draft plan which we hope to submit to the FCC shortly. I would appreciate any comments that you may have.

Please respond by September 22nd as we would like to submit by October 1st.

Thank you for your consideration and my best regards to the membership of your committee.

Sincerely yours,



Thomas E. Gibson  
Chairman

Enclosure

# State of Maryland Department of General Services

WILLIAM DONALD SCHAEFER  
Governor

EARL F. SEBODA, P.E.  
Secretary



DESIGN & CONSTRUCTION  
RECORDS MANAGEMENT  
PLANT MANAGEMENT  
SPACE MANAGEMENT  
LAND ACQUISITION  
PRINTING & PUBLICATION  
TELECOMMUNICATIONS  
PURCHASING & MATERIALS MANAGEMENT  
ADMINISTRATIVE & FISCAL SERVICES  
MULTISERVICE CENTERS

September 15, 1989

Mr. Thomas E. Gibson  
Chairman  
Region 28 Planning Committee  
2122 Sierra Road  
Plymouth Meeting, PA 19462

Dear Tom,

I have reviewed your draft of the Region 28 plan. I can find no problems or conflicts between our two plans as each has been run by the CETINC computer program allowing consideration for the edge effect.

The fact that both our plans include a standing committee to administer the plan and their committee responsibilities list includes coordination with neighboring regions, this should insure the future compatibility of our plans.

I am enclosing a copy of the Region 20 draft for your evaluation and comments. We hope to do the word smithing and other minor corrections within the next two weeks and be ready for submission to the FCC by mid to late October.

Your cooperation in this effort is greatly appreciated and my congratulations to you and your committee for the fine efforts put forth on your plan.

Sincerely,

  
Weldon P. Hale  
Chairman  
Region 20

Enclosure

TGIBSON.WH

Office of Telecommunications Management  
301 WEST PRESTON STREET, ROOM 1304, BALTIMORE, MARYLAND 21201 (301) 225-4205  
TTY: 1-800-666-6666  
O.C. Memo 565-0451



PENNSYLVANIA STATE POLICE  
DEPARTMENT HEADQUARTERS  
1800 ELMERTON AVENUE  
HARRISBURG, PA. 17110

September 22, 1989

Mr. Thomas E. Gibson  
Chairman  
Region 28 Planning Committee  
2122 Sierra Road  
Plymouth Meeting, Pennsylvania 19462

Dear Mr. Gibson,

We have carefully reviewed your Region 28 Plan and find that the inter regional coordination provisions are acceptable.

We appreciate being made a part of your planning process since your committee's inception. It is evident that much work has been done to complete your plan and we are pleased to provide our concurrence.

Please extend our best regards to the membership of your committee.

Sincerely yours,

A handwritten signature in dark ink, appearing to read 'John S. Holler Jr.', written over the typed name.

John S. Holler Jr.  
Chairman  
Region 36 Planning Committee  
c/o Pennsylvania State Police  
Headquarters  
Communications Division  
1800 Elmerton Ave.  
Harrisburg, Pennsylvania 17110  
717-787-0896

Buckle Up Pennsylvania

September 29, 1989

The Region 28 Planning Committee is pleased to submit its Regional Plan for your review and approval. The Committee has spent nearly eighteen months of effort in formulating the best possible plan to provide for the spectrum needs of the most possible agencies with a maximum utilization of spectrum available.

The Plan represents the best effort of 76 members representing 57 agencies and addresses all the concerns expressed by the Federal Communications Commission in its Report and Order terminating Docket 87-112.

Should you have any questions regarding this plan, please call me at (215) 828-8762.

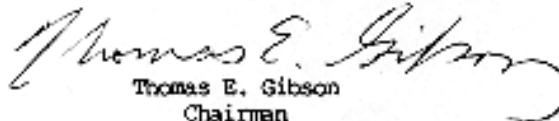
  
Thomas E. Gibson  
Chairman

REGION 28 PLANNING COMMITTEE  
2122 SIERRA ROAD  
PLYMOUTH MEETING, PA 19462  
215-828-8762

REGION 28 PLANNING COMMITTEE  
2122 SIERRA ROAD  
PLYMOUTH MEETING, PA 19462  
215-828-8762

September 29, 1989

Ms. Donna Searcy  
Secretary  
Federal Communications Commission  
1919 M Street NW  
Washington, D.C. 20554

Dear Ms. Searcy:

The Region 28 Planning Committee is pleased to submit its Regional Plan for the review and approval of the Federal Communications Commission. The Committee has spent nearly eighteen months of effort in formulating the best possible plan to provide for the spectrum needs of the most possible agencies with a maximum utilization of spectrum available.

The Plan represents the best effort of 76 members representing 57 agencies and addresses all the concerns expressed by the Federal Communications Commission in its Report and Order terminating Docket 87-112.

Should you have any questions regarding this plan, please call me at (215) 828-8762.

Sincerely yours,

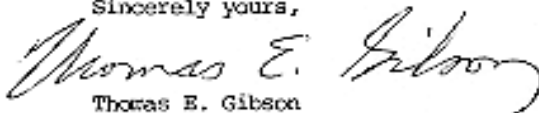
  
Thomas E. Gibson  
Chairman

cc: Robert Tall, Executive Director, APCO

REGION 28 PLANNING COMMITTEE  
2122 SIERRA ROAD  
PLYMOUTH MEETING, PA 19462  
215-828-8762

September 29, 1989

Mr. Ralph Haller  
Chief, Private Radio Bureau  
Federal Communications Commission  
2025 M Street NW  
Washington, D.C. 20554

Dear Mr. Haller:

The Region 28 Planning Committee is pleased to submit its Regional Plan for your review and approval. The Committee has spent nearly eighteen months of effort in formulating the best possible plan to provide for the spectrum needs of the most possible agencies with a maximum utilization of spectrum available.

The Plan represents the best effort of 76 members representing 57 agencies and addresses all the concerns expressed by the Federal Communications Commission in its Report and Order terminating Docket 87-112.

Should you have any questions regarding this plan, please call me at (215) 828-8762.

Sincerely yours,

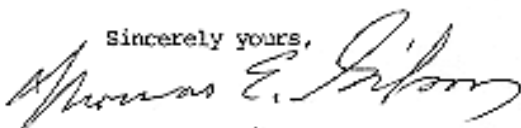

Thomas E. Gibson  
Chairman

cc: Robert Tall, Executive Director, APCD

REGION 28 PLAN  
(As defined in)  
FCC Gen. Docket No. 87-112

APPENDIX K-10

REGION 28 PLANNING COMMITTEE  
2122 SIERRA ROAD  
PLYMOUTH MEETING, PA 19462  
215-828-8762

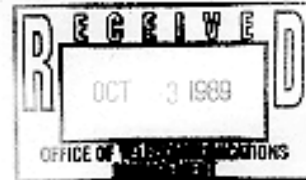

September 29, 1989

Dr. Thomas Stanley  
Chief Engineer  
Federal Communications Commission  
2025 M Street NW  
Washington, D.C. 20554

Dear Dr. Stanley:

The Region 28 Planning Committee is pleased to submit its Regional Plan for your review and approval. The Committee has spent nearly eighteen months of effort in formulating the best possible plan to provide for the spectrum needs of the most possible agencies with a maximum utilization of spectrum available.

The Plan represents the best effort of 76 members representing 57 agencies and addresses all the concerns expressed by the Federal Communications Commission in its Report and Order terminating Docket 87-112.

Should you have any questions regarding this plan, please call me at (215) 828-8762.

Sincerely yours,

A handwritten signature in cursive script that reads "Thomas E. Gibson".

Thomas E. Gibson  
Chairman

cc: Robert Tall, Executive Director, APCO



Local Government  
Police  
Fire  
Highway Maintenance  
Forestry - Conservation  
Special Emergency

APPENDIX K  
ADDENDUM NUMBER 1



Tri-State Radio Planning Committee  
(FCC-Region 8)  
One BCTE Plaza - 2nd Floor  
Jersey City, NJ 07306

October 3, 1989

Thomas E. Gibson Chairman  
Region 28 Planning Committee  
2122 Sierra Road  
Plymouth Meeting, PA 19462

Dear Tom:

As you requested in your letter of September 8, I have reviewed your plan paying particular attention to the frequency assignments especially in the area where Region 28 borders with Region 8. I believe, that without exception, there will not be any frequency assignment problems between our Regions. Therefore, I see no reason for you not to submit the plan as written.

Your Committee is to be congratulated on a job well done.

Sincerely,

A handwritten signature in cursive script that reads "Carroll F. White".

Carroll F. White  
Committee Coordinator  
Region 8

cc: H. DeGeneste, N. Coltri

APPENDIX K  
ADDENDUM NUMBER 2

REGION 28 PLANNING COMMITTEE  
2122 SIERRA ROAD  
PLYMOUTH MEETING, PA 19462  
215-828-8762

NOVEMBER 20, 1989

Allen L. Capwell  
Wyoming County Sheriff  
Chairman Region 55 Planning Committee  
145 North Main Street  
Warsaw, NY 14569

Dear Sheriff Capwell:

I am enclosing a copy of the Region 28 plan which is under review by the FCC. I would appreciate any comments that you may have.

I would appreciate a letter of concurrence once you have had an opportunity to review the plan.

Thank you for your consideration and my best regards to the membership of your committee.

Sincerely yours,

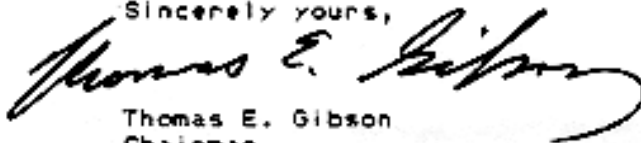

Thomas E. Gibson  
Chairman

Enclosure

RECEIVED  
COMMUNICATION  
90 FEB 12 PM 12:22

TO: Region 28 Planning Committee  
FROM: Tom Gibson, Chairman   
DATE: February 12, 1990  
RE: Plan Approval

It is my great pleasure to inform you that the Region 28 Plan was approved on February 2, 1990 by the FCC. The FCC review produced only minor problems which were easily resolved. Two addenda were required: a list of unassigned channels and proof of coordination with Region 35 (which we had overlooked as being partially adjacent to our region). In addition, the concurrence from Region 8 was received after we had already filed so that letter was added as a third addendum.

Copies of the addenda are included with this mailing so that all committee members will have the complete plan as accepted by the FCC.

Our next meeting is set for February 28th at 10:00 A.M. at the Bucks County Fire Training Academy. This will be a very important meeting as we must begin work on coordinating the channels which were assigned in the Plan and considering when we should open a second window for applications.

I look forward to seeing each of you at the meeting.